



LIGHT IS DESIGN

LA LUCE SECONDO PENTA

Light according Penta



pentalightgroup.it



pentalight.com



penta-arch.it



pcustomlight.it



arredoluce.com

Il design tra decorazione e contemporaneità di Penta Light, l'illuminazione tecnica di Penta Architectural, il made to measure di P Custom, le riedizioni dei maestri di Arredoluce. Dalla fusione di quattro realtà d'eccellenza del mondo dell'illuminazione è nato Penta Group: quattro brand, ciascuno con la propria autonomia, per quattro approcci progettuali accomunati dall'idea di trovare una sintesi tra funzionalità, tecnologia e bellezza.

The decorative yet contemporary design by Penta Light, the technical lighting by Penta Architectural, the made to measure by P Custom, the new editions of the Masters by Arredoluce. The fusion of these four outstanding companies in the lighting world gave birth to Penta Group: four brands, each with a strong characterization, four design approaches sharing the idea of finding a synthesis between functionality, technology and beauty.

PENTA

GEOGRAFIA DELLA LUCE

A light — geography



Ogni lampada è il risultato dell'incontro tra la luce e lo spazio. Un binomio perfetto che le lampade Penta arricchiscono con la qualità di un design unico, espressione di un'eleganza sofisticata e di una bellezza senza tempo.

Luce, spazio e bellezza sono anche il fil rouge di questo racconto che inizia a Milano, storica capitale del design made in Italy, attraversa il Veneto delle ville palladiane e arriva a Venezia, città depositaria della tradizione decorativa italiana e della lavorazione del vetro.

Una narrazione che è anche un viaggio attraverso le nostre geografie: da Milano – insieme alla Brianza il luogo del saper fare e della storia di Penta – al Veneto, nuovo approdo di un Gruppo che ha fatto dell'illuminazione di qualità, in ogni ambito, la sua filosofia.

Each lamp is the result of the encounter between light and space. A perfect match that Penta lamps enrich with the quality of a unique design, expression of refined elegance and timeless beauty.

Light, space and beauty are as well the common thread in this tale that starts in Milan, historical capital of Italian design, crosses the Palladian Villas in Veneto and lands in Venice, beating heart of the Italian decorative tradition and the secrets of processing glass.

A tale which is also a journey through our geographies: from Milan – together with Brianza the place of know-how and of Penta history – straight to Venice, new landing port for a Group that has declared quality lighting its philosophy, in every way.

INDEX

A

| | |
|--------------|----|
| ANGOLO | 16 |
| ACORN | 24 |
| APRILE | 30 |

B

| | |
|-----------|----|
| BAG | 36 |
|-----------|----|

C

| | |
|-------------|----|
| C'HI | 40 |
| CHINA | 52 |
| CLASH | 62 |
| CLIP | 66 |

E

| | |
|-----------------|----|
| ELISABETH | 72 |
| ENOKI | 84 |

F

| | |
|------------|----|
| FEEL | 90 |
|------------|----|

G

| | |
|-----------|-----|
| GLO | 100 |
|-----------|-----|

J

| | |
|------------------|-----|
| JACQUELINE | 124 |
| JEI JEI | 134 |
| JE SUIS | 140 |

K

| | |
|-------------|-----|
| KLINT | 148 |
|-------------|-----|

L

| | |
|------------|-----|
| LAB | 154 |
| LIT | 160 |
| LULA | 170 |

M

| | |
|------------|-----|
| MAMÌ | 180 |
| MOM | 202 |

N

| | |
|---------------|-----|
| NARCISO | 226 |
|---------------|-----|

P

| | |
|-------------|-----|
| POLAR | 244 |
| POP | 250 |

S

| | |
|-------------|-----|
| SPOON | 256 |
| STORM | 272 |

T

| | |
|-------------|-----|
| TAAAC | 280 |
|-------------|-----|

W

| | |
|--------------|-----|
| WONDER | 286 |
| WOODY | 292 |

Our Heritage

| | |
|--------------------------|-----|
| NEW CLASSIC | 300 |
| TIC & TOC | 312 |
| TOSCA | 320 |
| BRIDGET COLLECTION | 326 |

Sospensioni in tessuto

Fabric suspensions

| | |
|-----------------------|-----|
| CILINDRO | 332 |
| CILINDRO ALTO | 334 |
| CILINDRI BASSI | 336 |
| CILINDRO DOPPIO | 338 |
| UP-DOWN | 340 |
| LUXURY | 342 |
| SLIDE | 344 |
| RETTANGOLARE | 346 |
| VANITY | 348 |
| CLUB HOUSE | 350 |

SOSPENSIONE / SUSPENSION

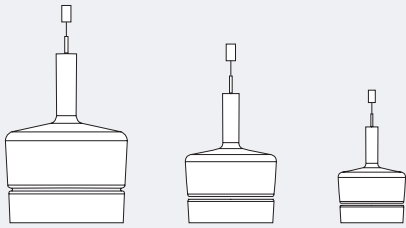

ACORN.....24

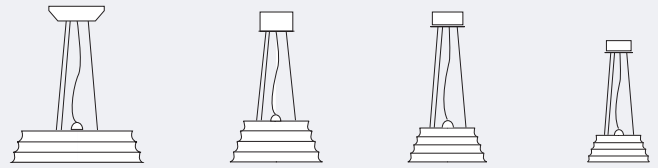

C'HI.....40

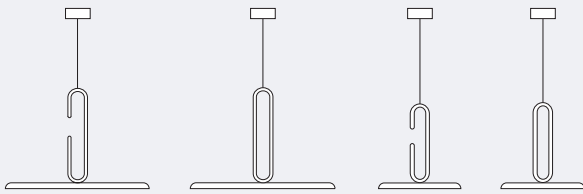

CLIP.....66

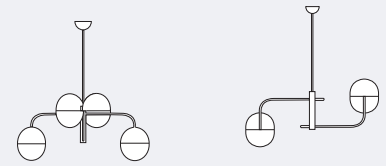

ELISABETH.....72

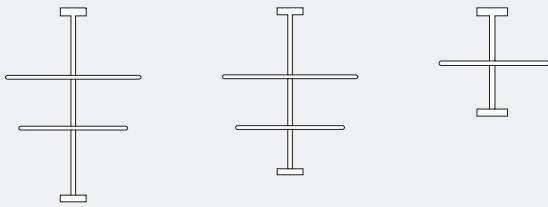

FEEL.....90

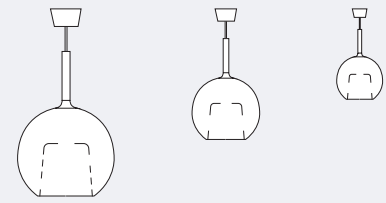

GLO.....100

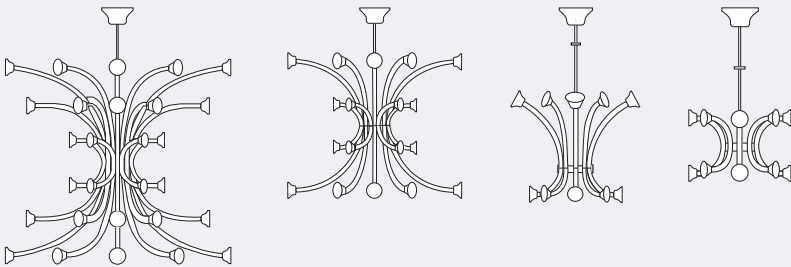

JEI JEI.....134

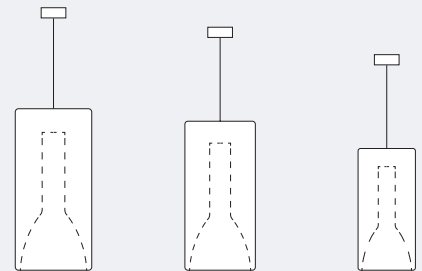

LIT.....160

SOSPENSIONE / SUSPENSION

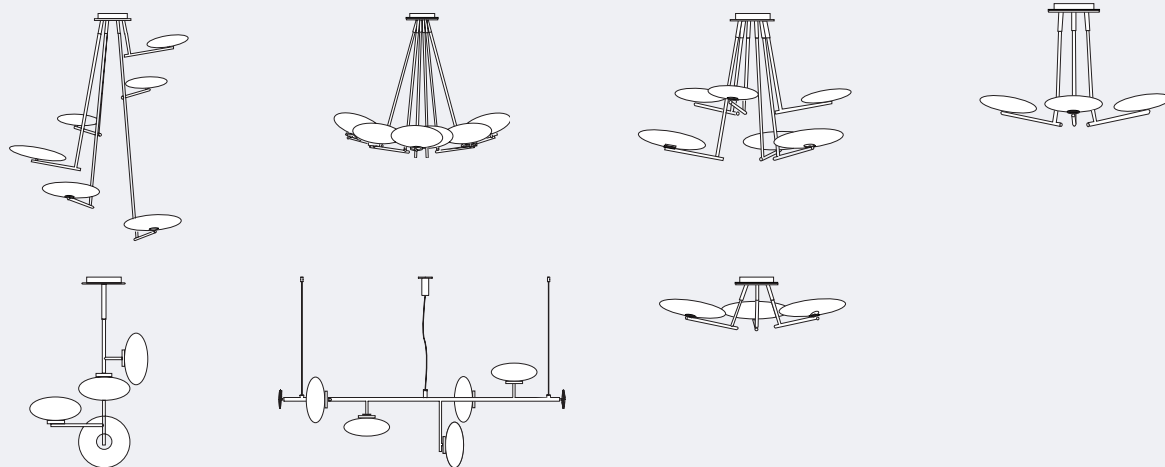

MAMI.....180

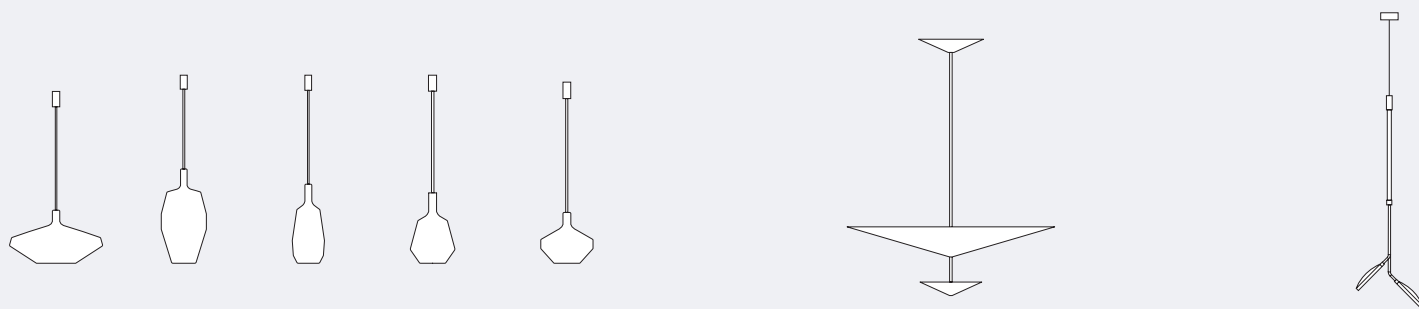

MOM.....202

NARCISO.....226

SPOON.....256

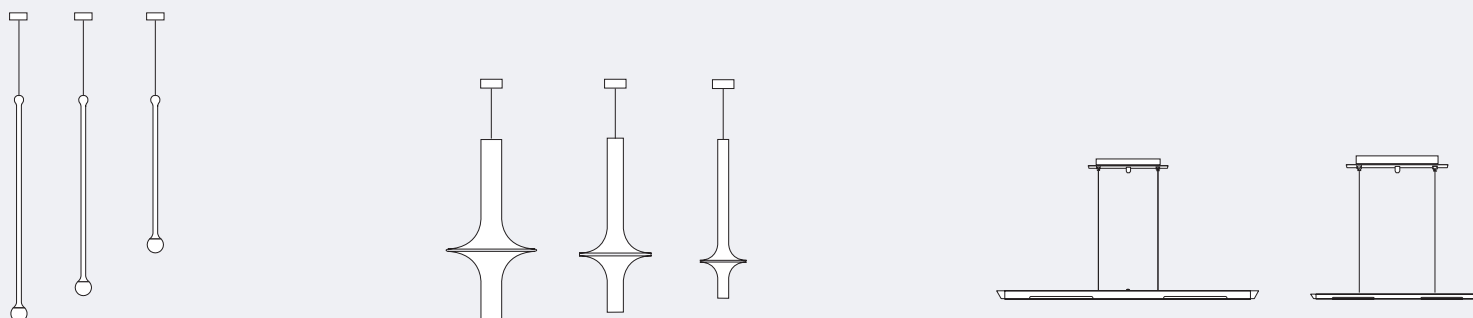

STORM.....272

WONDER 286

WOODY.....292

APPLIQUE / WALL

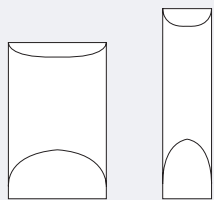

APRILE30



C'HI.....50

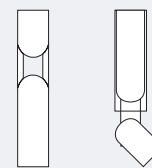

CLASH62

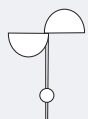

ELISABETH80



ENOKI.....84

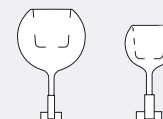

GLO120

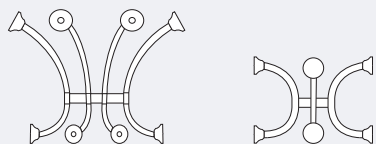

JEI JEI138



MAMÌ.....198

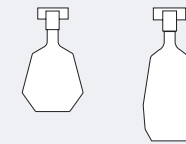

MOM220



POP.....250

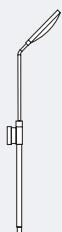

SPOON.....268



BRIDGET COLLECTION326

TAVOLO / TABLE

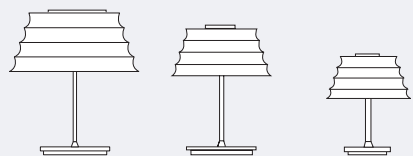

C'HI.....46



CHINA.....52

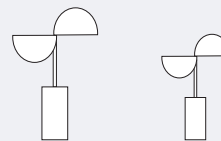

ELISABETH74

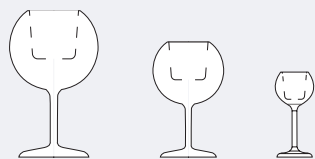

GLO.....112

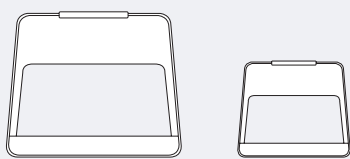

JACQUELINE.....124



JE SUIS.....140

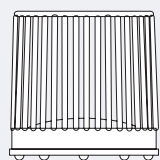

KLINT148

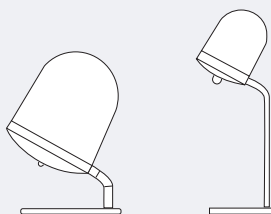

LULA170



MAMÌ.....184

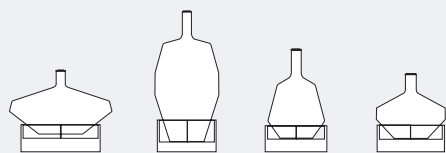

MOM216

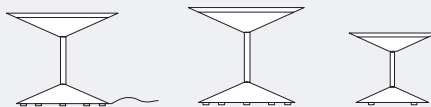

NARCISO.....226



POLAR247



SPOON..... 262

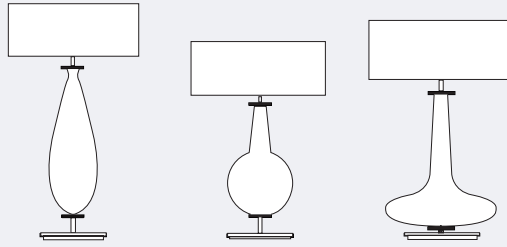

NEW CLASSIC 304

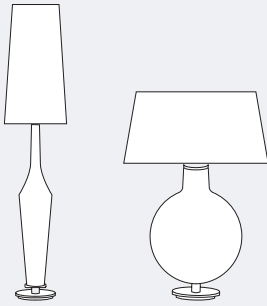

TIC & TOC..... 312

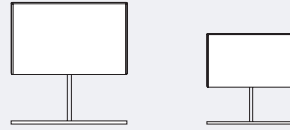

TOSCA 322

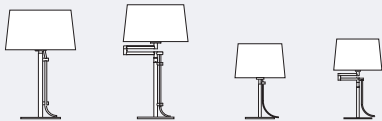

BRIDGET COLLECTION..... 326

TERRA / FLOOR

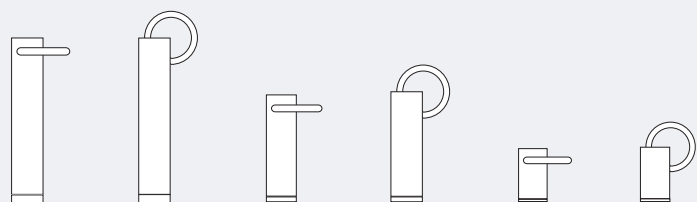

ANGOLO 16

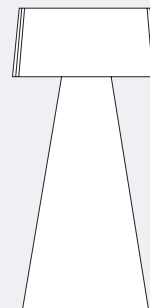

BAG 36



C'HI 48

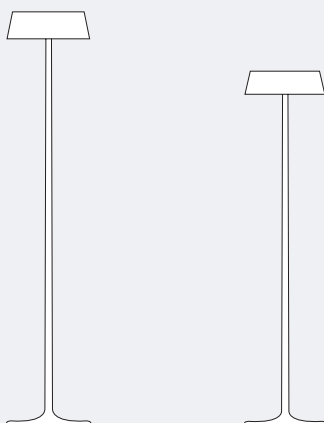

CHINA 56

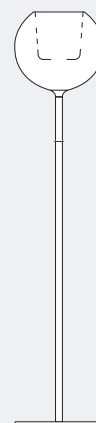

GLO 116



JE SUIS 144

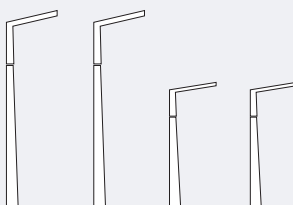

LAB 154

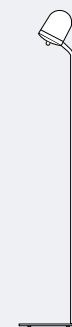

LULA 176

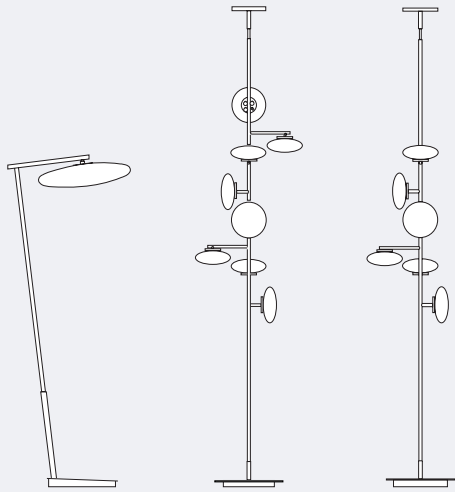

MAMÌ..... 180

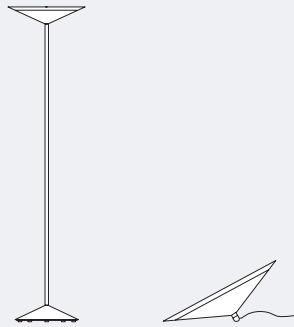

NARCISO..... 237



POLAR..... 244



SPOON..... 264

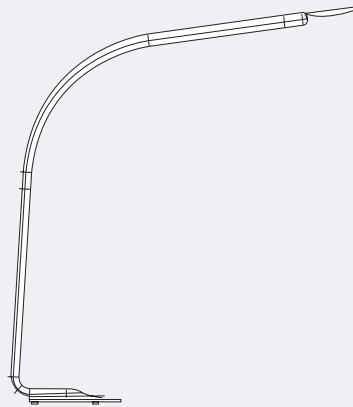

TAAAC..... 280

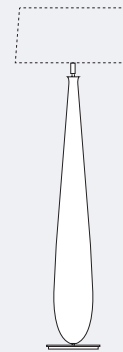

NEW CLASSIC..... 300



TOSCA..... 320

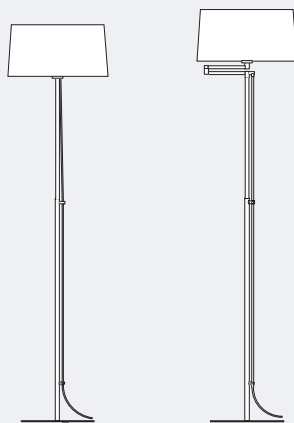

BRIDGET COLLECTION..... 328

SOSPENSIONI, PLAFONIERE, APPLIQUES IN TESSUTO / FABRIC PENDANTS, CEILINGS AND APPLIQUES

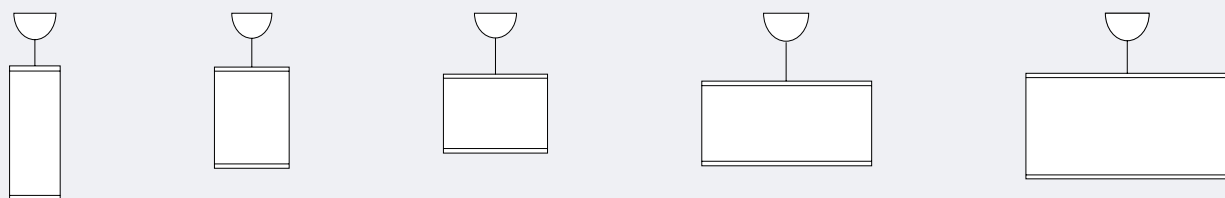

SOSPENSIONI IN TESSUTO / FABRIC SUSPENSIONS 360 / 363

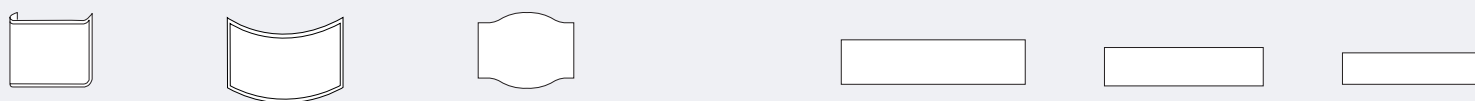

APPLIQUES IN TESSUTO / FABRIC APPLIQUES 363

PLAFONIERE IN TESSUTO / FABRIC CEILINGS 362

FAMIGLIE / FAMILIES

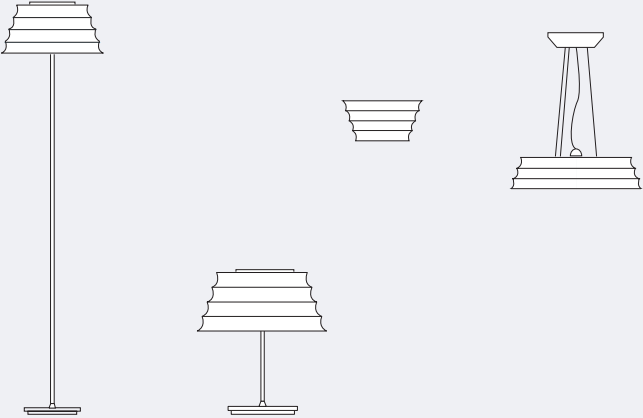

C'HI..... **40**

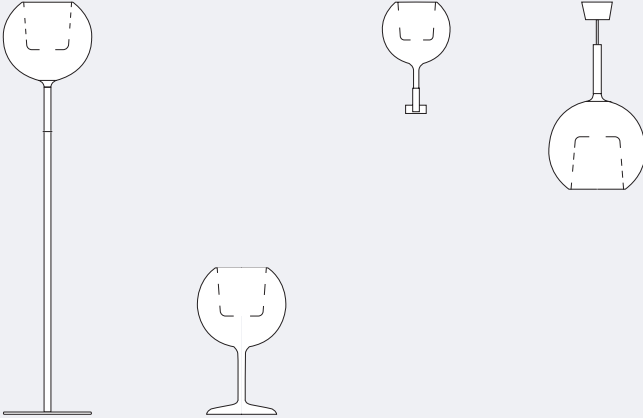

GLO..... **100**

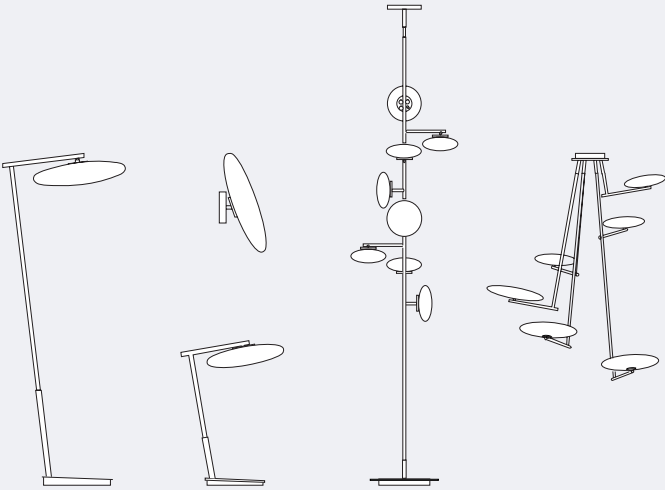

MAMÌ..... **180**

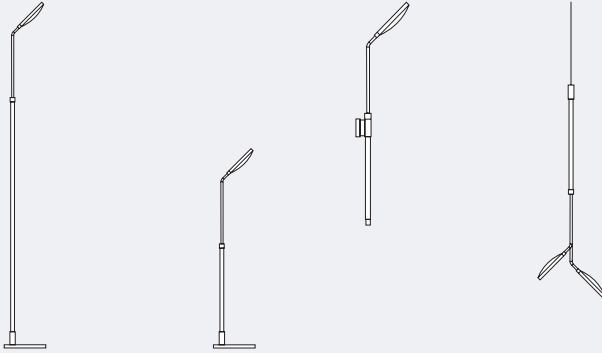

SPOON..... **256**





CRISTIÁN MOHADED 2018

ANGOLO

Between essentiality — and solidness

Un elemento illuminante dalle linee essenziali e una struttura monoblocco in pietra o legno: Angolo è una scultura di luce che unisce sapientemente pulizia delle forme e ricchezza materica, per atmosfere sofisticate sia all'interno che all'esterno.

A single illuminating element with essential lines and a stone or wood monobloc: Angolo is a light sculpture combining cleanliness of shapes and material richness, to create an elegant atmosphere, both indoors and outdoors.

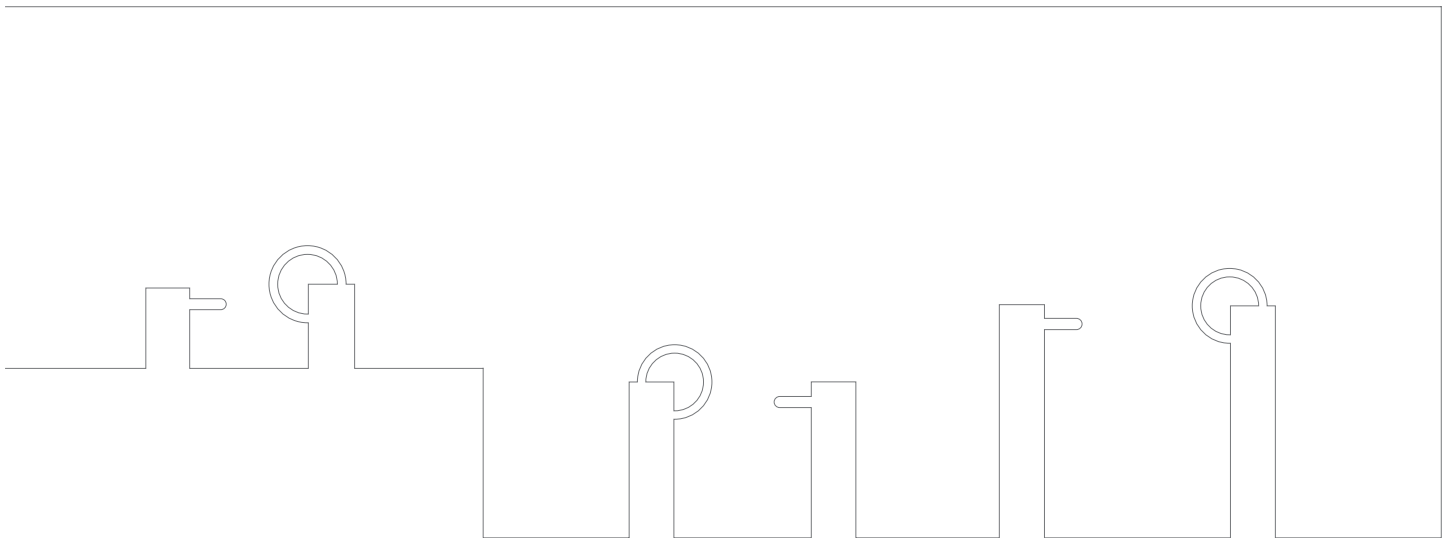













ANGOLO *Cristián Mohaded, 2018*

1832

Lampada da terra con anello verticale o orizzontale in metallo verniciato opaco nei colori oro, oro rosa e grafite. Base in marmo Emperador spazzolato, Ceppo grezzo o cemento con protezione IP65 per outdoor. Base in legno rovere grafite o rovere cognac con protezione IP20 per indoor.

Floor lamp with vertical or horizontal metal ring in graphite, gold and pink gold matt finishes. Base in brushed Emperador marble, Ceppo raw, cement with protection IP65 for outdoor. Base in cognac or graphite oak with protection IP20 for indoor.

STRUTTURA / STRUCTURE IP65



STRUTTURA / STRUCTURE IP20

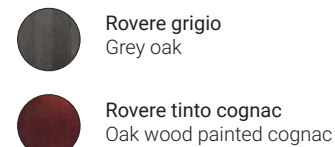

ANELLO / RING



SORGENTE / SOURCE

9 W LED 3000 K - 1100 lm
Dimmer 1-10V

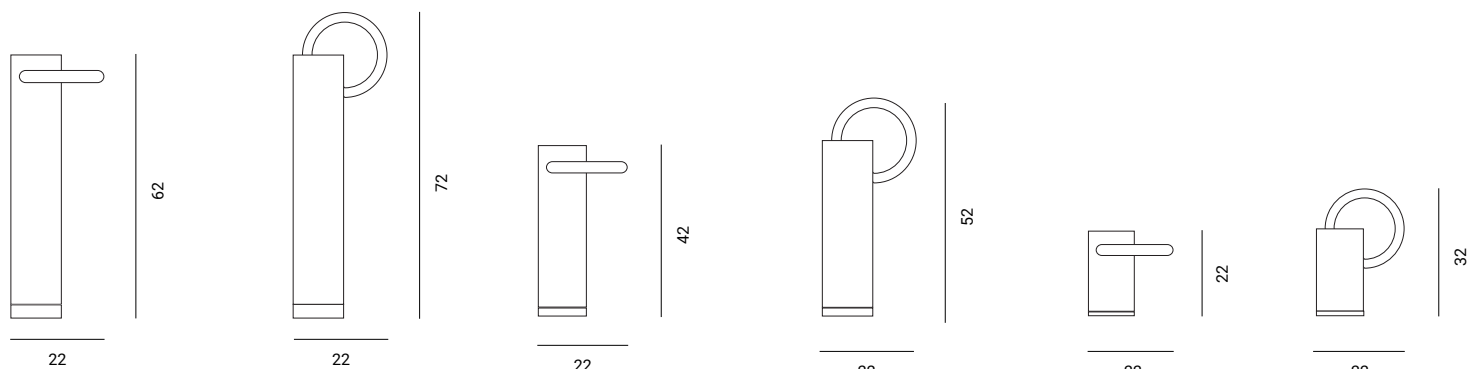

1832-1W
large horizontal
IP65

1832-1J
large vertical
IP65

1832-1K
medium horizontal
IP65

1832-1Z
medium vertical
IP65

1832-1Y
small horizontal
IP65

1832-1X
small vertical
IP65

1832-15
large horizontal
IP20

1832-14
large vertical
IP20

1832-13
medium horizontal
IP20

1832-12
medium vertical
IP20

1832-11
small horizontal
IP20

1832-10
small vertical
IP20

MATTEO BIANCHI 2015

ACORN

The unbearable lightness — of concrete

La materialità del cemento si fonde con la leggerezza del vetro nella lampada a sospensione Acorn, nata per illuminare gli spazi all'esterno e protagonista di quelli all'interno. Il cemento, spatolato a mano, fa filtrare una luce calda e avvolgente.

The materiality of concrete merges with the lightness of glass in the suspension lamp Acorn, born to illuminate outdoor spaces yet protagonist indoors.

The hand trowelled concrete leaks a warm, enveloping light.

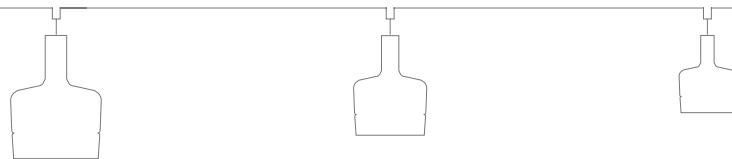









ACORN *Matteo Bianchi, 2015*

1501

Lampada sospensione con diffusore in cemento e vetro satinato o trasparente. Protezione IP44 contro gli spruzzi d'acqua da ogni direzione. Disponibile in tre dimensioni: large, medium e mini. Utilizzabile come elemento singolo o multiplo.

Pendant lamp with shade in concrete and frosted or transparent glass. Protection IP44 against water from any direction. Available in three sizes: large, medium and mini, as single element or in cluster.

STRUTTURA / STRUCTURE

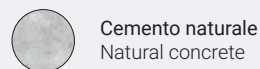

VETRO / GLASS

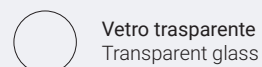
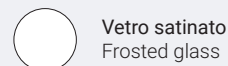

SORGENTE / SOURCE

1501-23
20 W LED 3000 K - 1700lm
Dimmable Triac / 0-10V

1501-22
15W LED 3000 K - 1300lm
Dimmable Triac / 0-10V

1501-21
8W LED 3000 K - 650lm
Dimmable Triac / 0-10V

SOSPENSIONE / SUSPENSION

1501-23
large

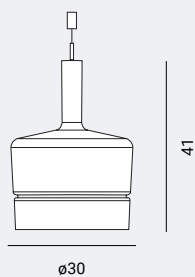

1501-22
medium

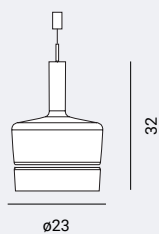

1501-20
mini

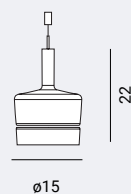

Rosone
Canopy

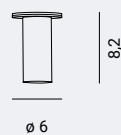

Piastre a pag. 364
plates p. 364

NICOLA GALLIZIA 2017

APRILE

Light — in April

Un quadro luminoso capace di far vibrare le pareti con una luce delicata come quella del sole in primavera. Aprile è un'applicque liberamente orientabile che esplora l'eleganza della luce, più intensa da un lato e più morbida dall'altro.

A luminous painting, capable of making the walls vibrate with a delicate light such as the sun in spring. Aprile is a freely adjustable wall lamp which explores the deep elegance of light, more intense on one side and softer on the other.





*Exploring —
the deep elegance of light*





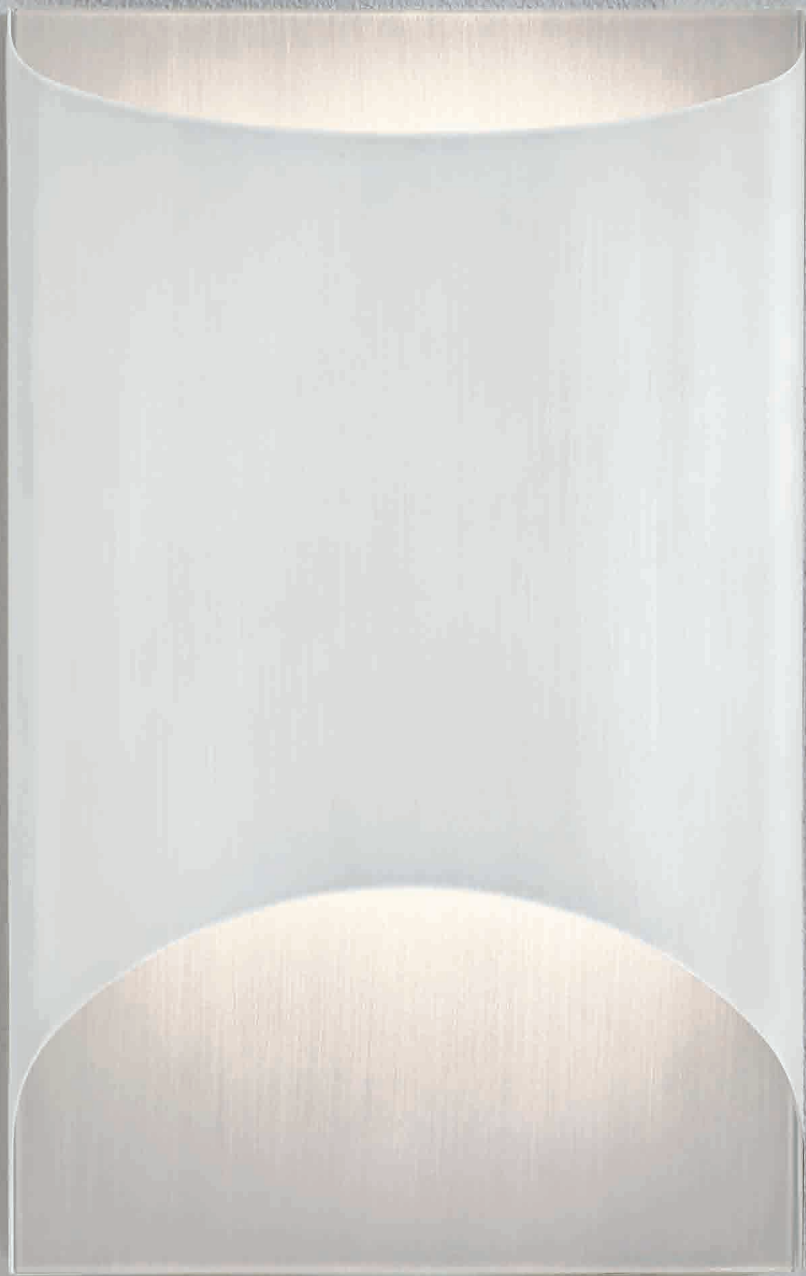

APRILE *Nicola Gallizia, 2017*

1649

Applique realizzata in metallo nelle finiture: acciaio spazzolato, bronzo spazzolato e verniciato bianco.

Wall lamp with metal structure in the finishes: brushed steel, brushed bronze and white varnished.

STRUTTURA / STRUCTURE

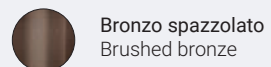
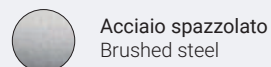

SORGENTE / SOURCE

2x6W LED 3000 K - 2x600 lm
Dimmable Triac / 0-10V

APPLIQUE / WALL

1649-30

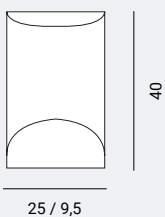

1649-31

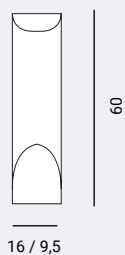

CARLO COLOMBO 2007

B A G

A monolith — of light

Prima lampada da esterni della collezione, Bag è un abat-jour in versione maxi realizzato in espanso termoplastico. Un volume monolitico e imponente per una luce di grande atmosfera.

First outdoor lamp of the collection, Bag is a giant version of a table lamp, made in thermo-plastic. A monolithic and imposing volume for a light that creates great atmosphere.





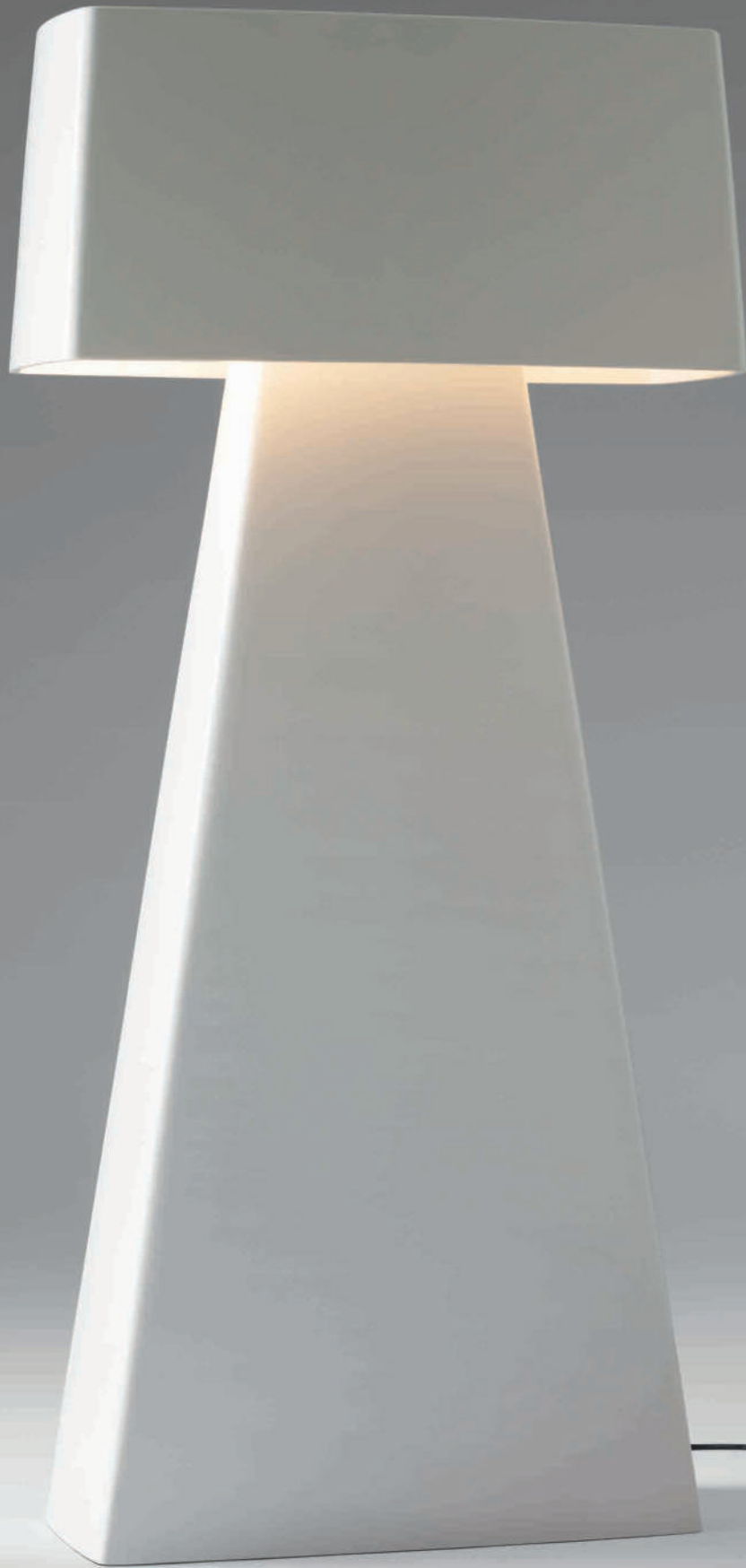

BAG *Carlo Colombo, 2007*

0802

Lampade da esterno in espanso termoplastico nei colori lucidi bianco e nero. Protezione IP44.

Outdoor lamps in thermo-plastic expansion in the glossy colours: white, black. Protection IP44.

STRUTTURA / STRUCTURE

 **Bianco lucido**
Glossy white

 **Nero lucido**
Glossy black

SORGENTE / SOURCE

1 x 5W LED E14 sup.
2 x 5W LED E14 inf.

TERRA / FLOOR

0802-1X

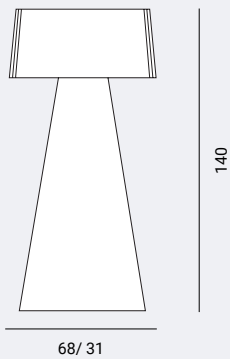

UMBERTO ASNAGO 1999

C ' H I

Play of shadows — play of light

Un classico della nostra collezione, C'hi si riconosce dal paralume in vetro, che con le sue onde delicate disegna luci e ombre sulle pareti e nello spazio. Una famiglia completa formata da lampade a sospensione, da tavolo, da terra e applique.

You can recognize our classic C'hi by its glass shade that, with its delicate waves, gently plays with lights and shadows on the walls and in the space. A complete collection of suspension, table, floor and wall lamps.

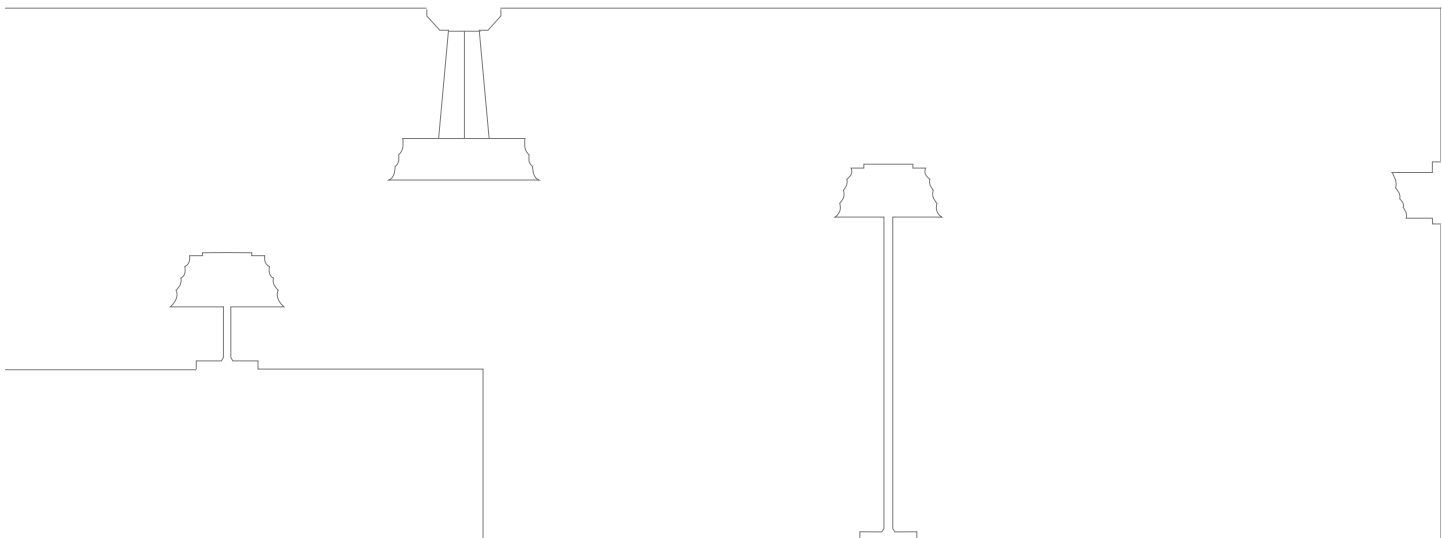





*Delicate waves gently
— play with lights*

















C'HI *Umberto Asnago, 1999*

9907

Lampade con struttura in metallo nichel satinato. Diffusore esterno in vetro soffiato nei colori: argento, trasparente, bianco, sabbia. Diffusore interno in vetro acidato.

Lamps with structure in nickel satin metal. Outer shade in blown glass in the following colours: silver, transparent, white, sand. Inner shade in mat glass.

STRUTTURA METALLO / METAL STRUCTURE

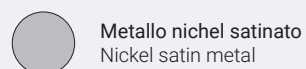

DIFFUSORE ESTERNO / OUTER SHADE

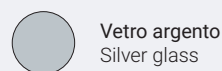
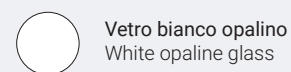
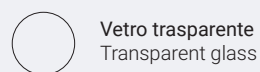

SORGENTE / SOURCE

9907-03
1 x 10W LED E27

9907-24
3 x 10W LED E27

9907-02
1 x 10W LED E27

9907-23
1 x 10W LED E27

9907-01
1 x 5W LED E14

9907-22
1 x 10W LED E27

9907-10
1 x 10W LED E27 

9907-21
1 x 5W LED E14

9907-33
1 x 16W LED R7s 117 mm

9907-31
1 x 16W LED R7s 117 mm

TAVOLO / TABLE

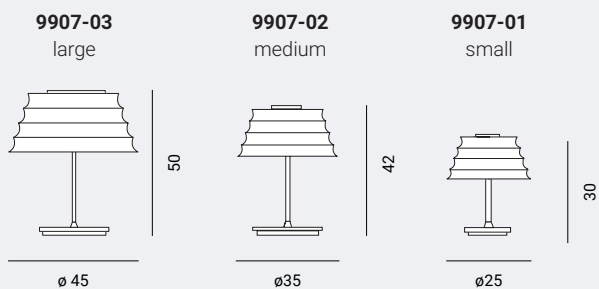

SOSPENSIONI / SUSPENSION

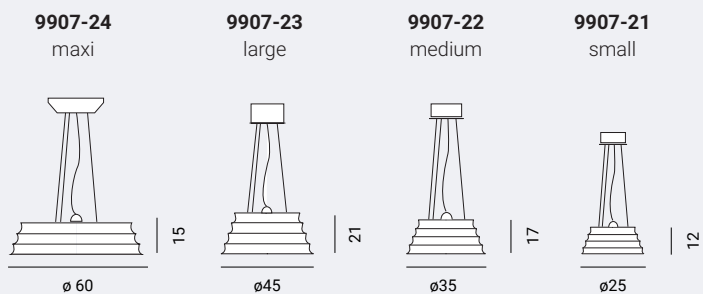

APPLIQUE / WALL

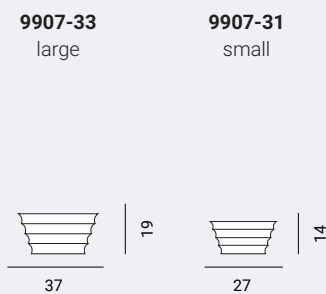

TERRA / FLOOR

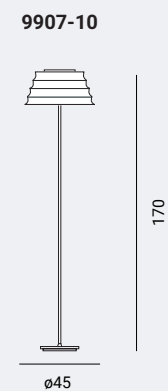

NICOLA GALLIZIA 2003-2007
PREMIO 2008: GOOD DESIGN AWARD

CHINA

The beauty — of a soft light

Un'elegante lampada da lettura che diffonde una luce soffusa grazie al basamento riflettente. La ricchezza delle finiture, dal bianco lucido all'oro, permette di interpretare China in modo sempre diverso a seconda del contesto.

An elegant reading lamp which spreads a soft light through its reflecting base. The different finishings, from glossy white to gold, allow to interpret China in a way that is always different, according to the context.

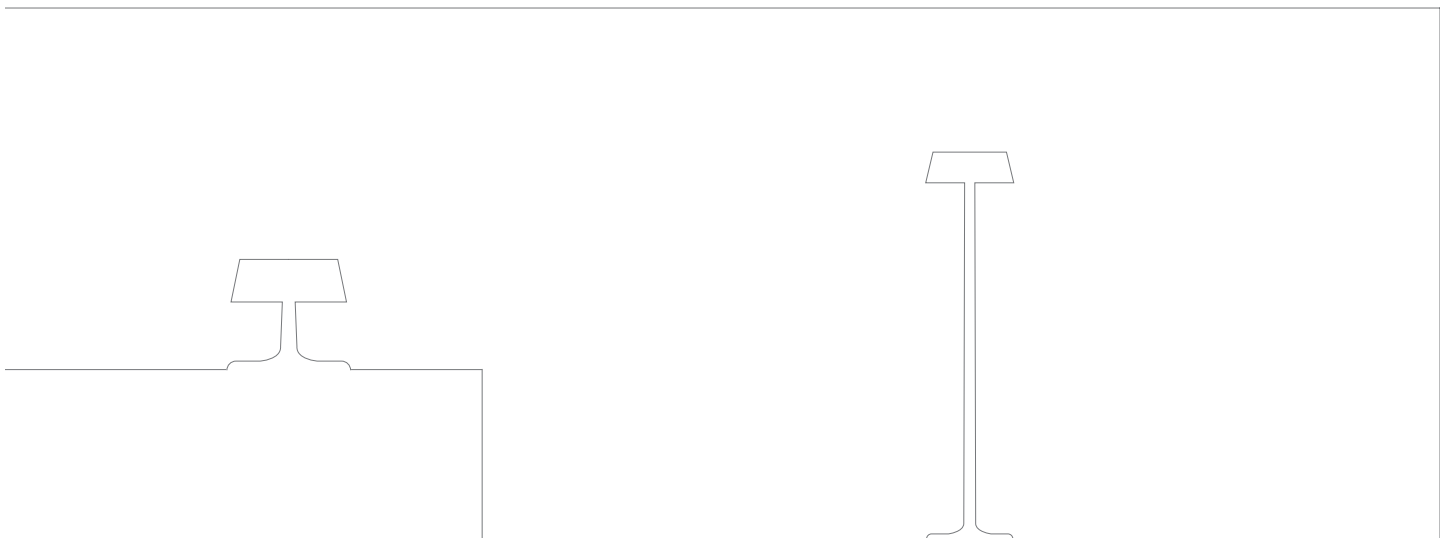



*Always different,
— according to the context*











Bianco lucido
Glossy white



Grafite opaco
Mat graphite



Maron glacé opaco
Mat maron glacé



Rosso opaco
Mat red





CHINA *Nicola Gallizia, 2003/2007*

0308

Lampade con struttura in metallo tornito in lastra. Verniciato opaco nei colori: rosso, maron glacé, bronzo, oro, oro rosa, grafite. Verniciato bianco lucido.

Lamps with metal structure. Matt varnished in the colours: red, maron glacé, bronze, gold, rose gold, graphite and glossy white varnished.

STRUTTURA METALLO / METAL STRUCTURE



SORGENTE / SOURCE

0308-00
3 x 5W LED E14 

0308-01
2 x 5W LED E14

0308-12
3 x 5W LED E14 

0308-11
3 x 5W LED E14 

TAVOLO / TABLE

0308-00
medium

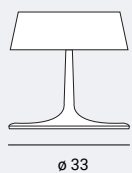

ø 33

32

0308-01
small

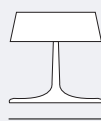

ø 23

22,5

TERRA / FLOOR

0308-12
high



ø 33

160

0308-11
low



ø 33

115

CLASH

Modern shapes — futuristic finishings

Clash è un'applique che combina la leggerezza del vetro e la forza del metallo per creare un oggetto dall'estetica moderna e sofisticata, reso futuristico dalle finiture in peltro e bronzo. La parte inferiore è orientabile, una caratteristica funzionale prima che estetica.

Clash is a wall lamp combining the lightness of glass and the strength of metal to create a modern and sophisticated object, with a futuristic touch given by pewter and bronze finishings. The lower part is adjustable, a functional feature rather than an aesthetic one.

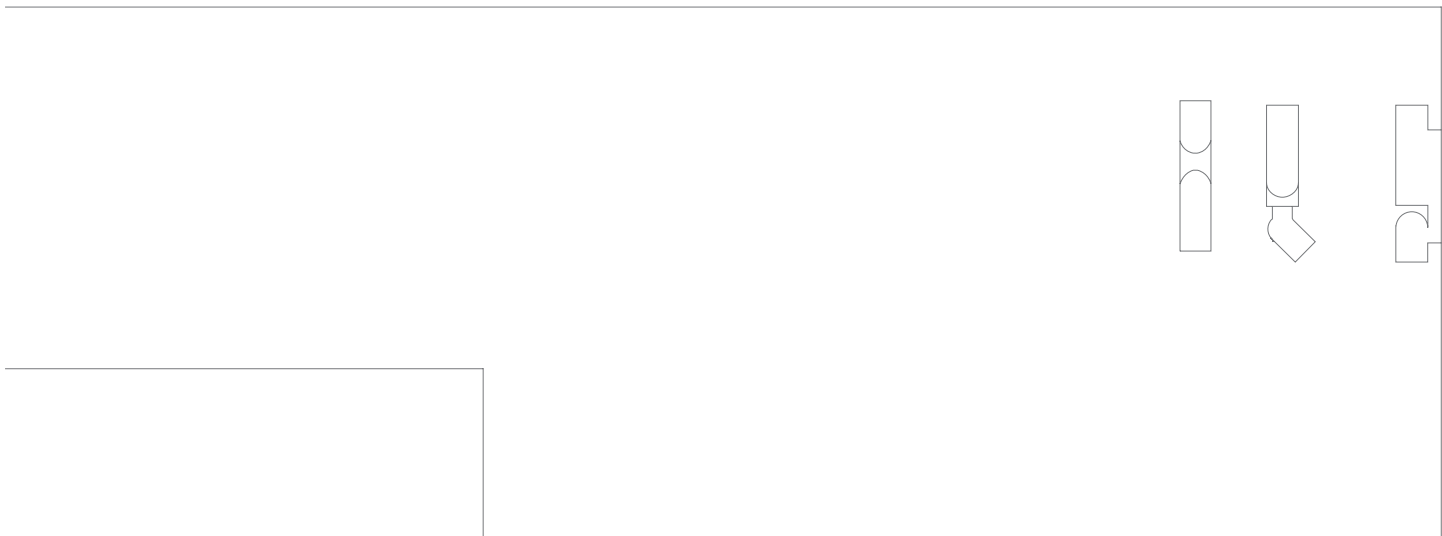



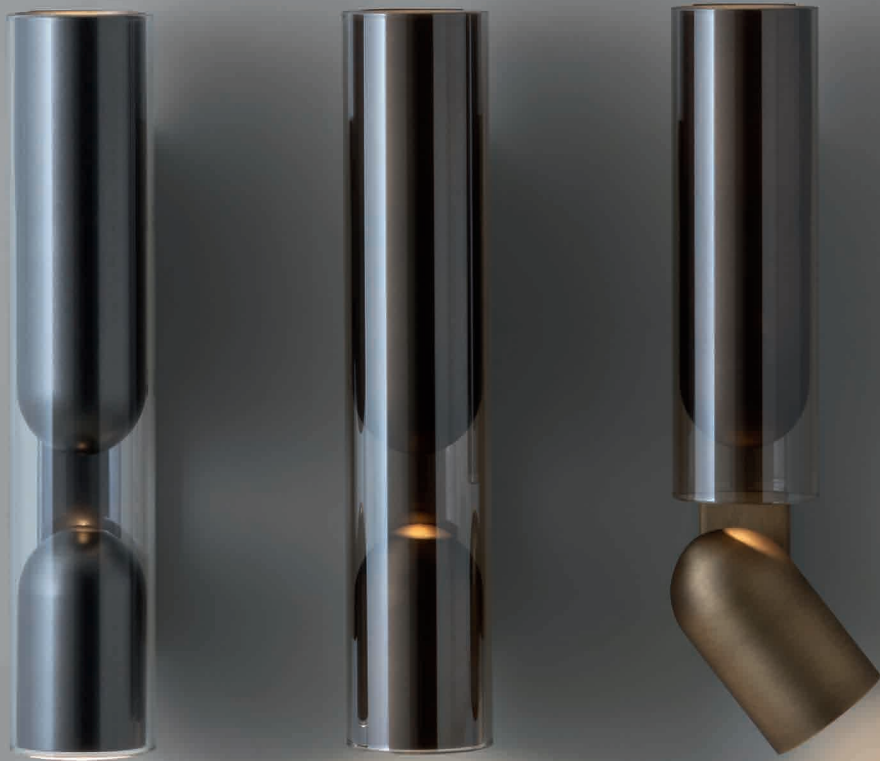

CLASH *Artefatto, 2017*

1699

Applique con struttura interna in metallo nelle finiture grafite o bronzo spazzolato e struttura esterna in vetro trasparente o fumé.

Wall lamp with inner structure in metal in the finishes graphite or brushed bronze and outer structure in transparent or fumé glass.

STRUTTURA METALLO / METAL STRUCTURE

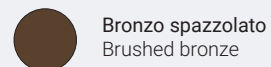
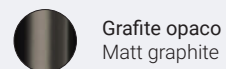

VETRO / GLASS

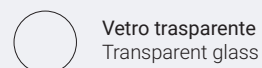

SORGENTE / SOURCE

1699-30
2x 6W LED GU10

1699-31
2x 6W LED GU10

APPLIQUE / WALL

1699-30

1699-31

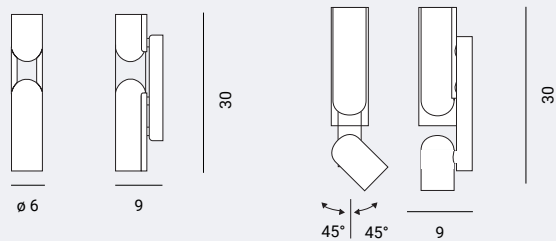

CLIP

Light — as a necklace

Clip è una collezione di lampade a sospensione caratterizzata da un disco sottile accoppiato a un'asola, aperta o chiusa, agganciata al cavo di sostegno. Un accessorio dall'estetica contemporanea, un sofisticato gioiello da soffitto.

Clip is a collection of suspension lamps defined by a thin disc coupled with a slot, open or closed, hooked to the support cable. An accessory from contemporary aesthetics, a glamorous ceiling jewel.

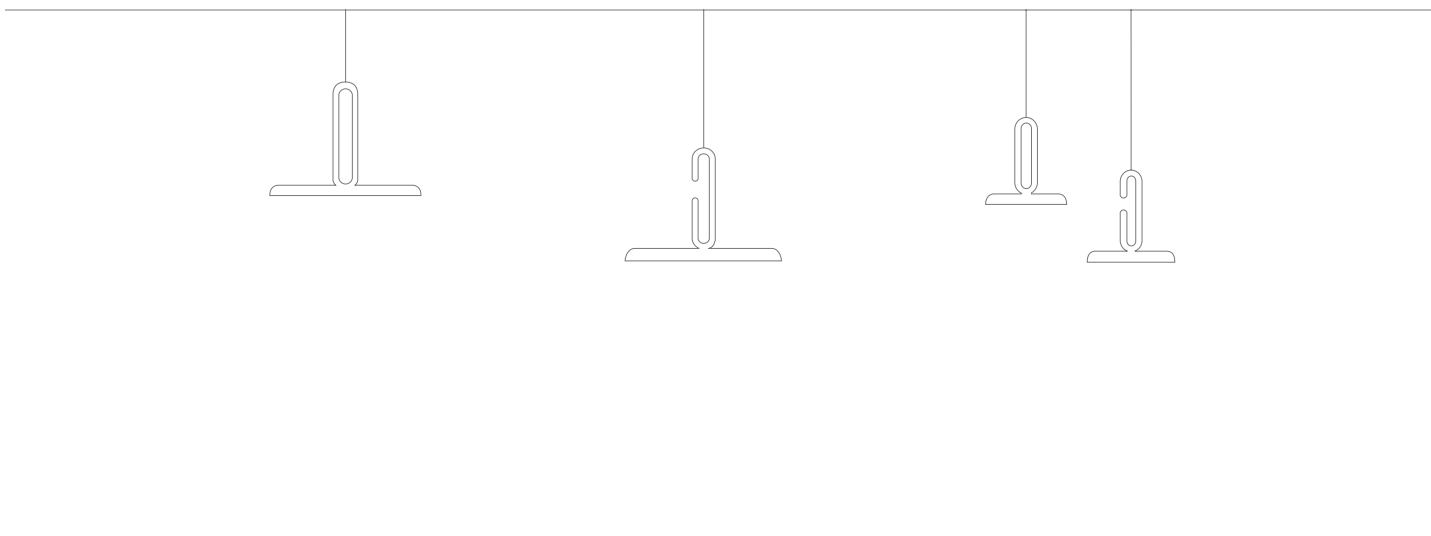





*A contemporary and glamorous
— ceiling jewel*





CLIP *Daniel Debiasi & Federico Sandri, 2017*

1707

Sospensioni con struttura in metallo nelle finiture lucide o opache: oro, oro rosa e grafite. Disponibile con anello aperto o chiuso, in due dimensioni, large o mini. Rosone singolo nelle stesse finiture della struttura. Utilizzabile come elemento singolo o multiplo.

Pendant lamps with metal structure in glossy or matt finishes: gold, rose gold and graphite. Available with open or close ring, in two sizes, large or mini. Single canopy in the same finishes of the structure. Available as single element or in cluster

STRUTTURA METALLO / METAL STRUCTURE



Oro lucido o opaco
Glossy or matt gold



Oro rosa lucido o opaco
Glossy or matt rose gold



Grafite lucido o opaco
Glossy or matt graphite

SORGENTE/ SOURCE

1707-24
16W LED 3000 K- 1900 lm

1707-22
7W LED 3000 K- 850 lm

1707-23
16W LED 3000 K- 1900 lm

1707-21
7W LED 3000 K- 850 lm

SOSPENSIONE / SUSPENSION

1707-24
large open

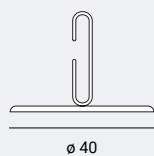

1707-23
large closed

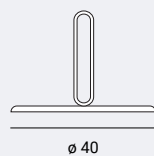

1707-22
mini open

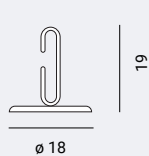

1707-21
mini closed

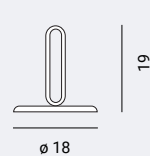

Rosone
canopy



Piastre a pag. 364
plates p. 364

CARLO COLOMBO 2017

ELISABETH

The precious side — of light

Un gioco astronomico di semisfere ispira la collezione Elisabeth – dalla più composta versione da tavolo alle suggestioni art déco della sospensione.

Metalli lucidi e marmo di Carrara impreziosiscono la pulizia formale dei volumi.

Elisabeth collection is inspired by an astronomical game of hemispheres: from the linear version of the table lamp to the suspension lamp, reminiscent of art deco. The formal cleanliness of the volumes is enriched by glossy metal and Carrara marble.

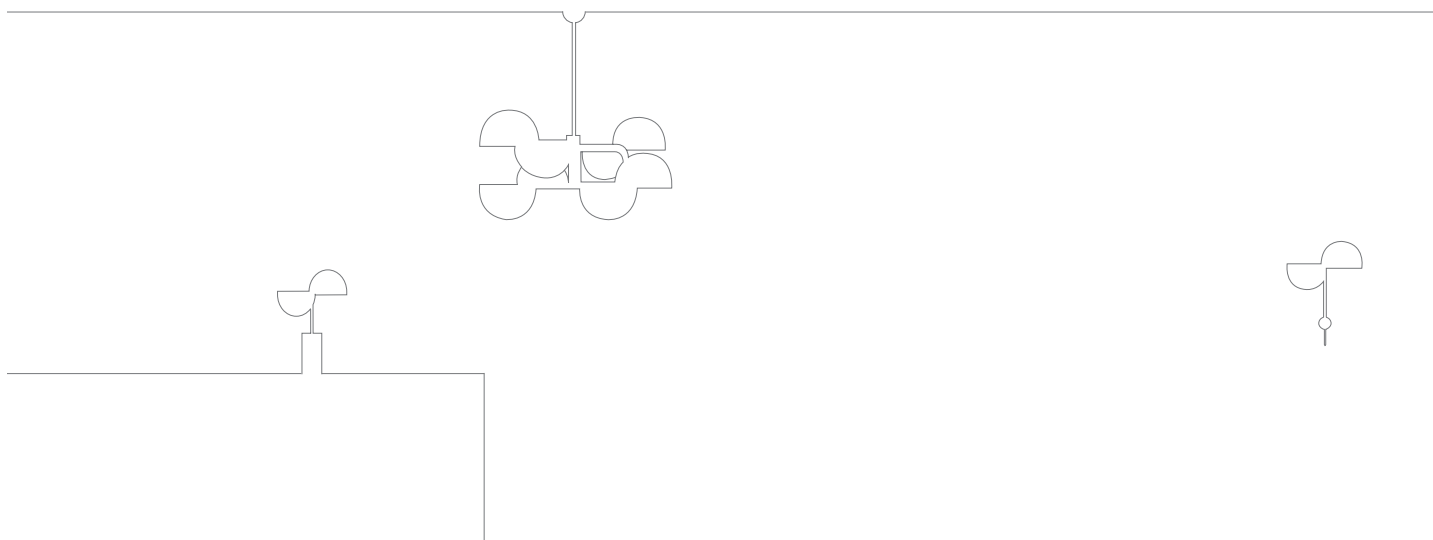











VENICE











ELISABETH *Carlo Colombo, 2017*

1711

Lampade con struttura in metallo nichel nero lucido.

Lampada da tavolo disponibile con base in marmo bianco di Carrara o con base in metallo.

Lamps with structure in glossy black nickel. Table lamp available with base in Carrara white marble or in metal.

STRUTTURA METALLO / METAL STRUCTURE



Cromo nero lucido
Glossy black chrome

BASE / BASE



Marmo bianco Carrara
White Carrara marble



Cromo nero lucido
Glossy black chrome

SORGENTE / SOURCE

1711-03
2 x 8W LED 3000 K - 2x650 lm

1711-23
8 x 10W LED 3000 K - 8x900 lm

1711-01
2 x 6W LED 3000 K - 2x450 lm

1711-21
4 x 10W LED 3000 K - 4x900 lm

1711-30
2 x 6W LED 3000 K - 2x450 lm

TAVOLO / TABLE

1711-03
large

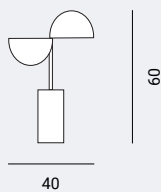

1711-01
small

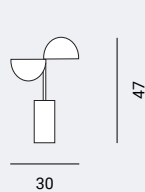

SOSPENSIONE / SUSPENSION

1711-23
large

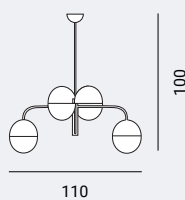

1711-21
small

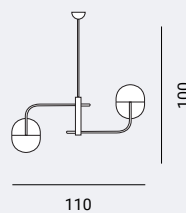

APPLIQUE / WALL

1711-30

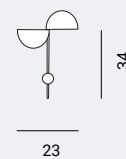

DEBIASI & SANDRI 2017

ENOKI

The splendour — of art deco

Applique che riprende forme art déco combinando una lamina di metallo a una semicupola sporgente, Enoki vive come oggetto singolo o combinata ad altri elementi simili, anche con orientamenti diversi.

Resuming shapes from art deco, this wall lamp combines a metal sheet with a protruding half-dome. Enoki can be a single design object or combined with other similar elements, assembled with different orientations.

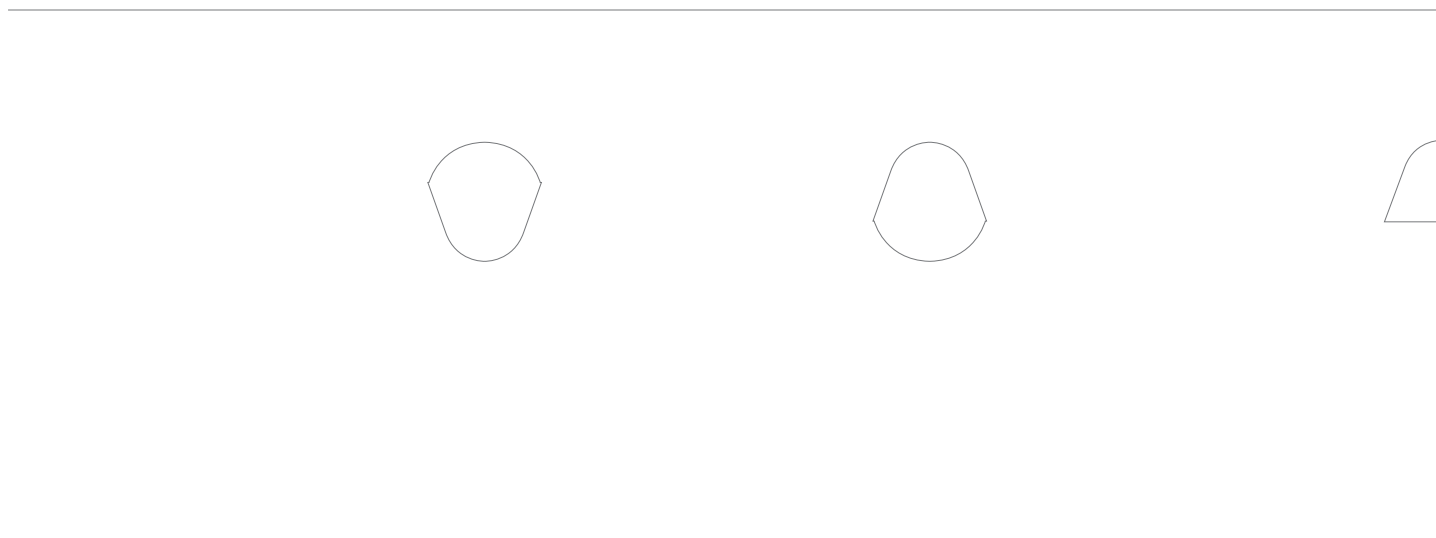







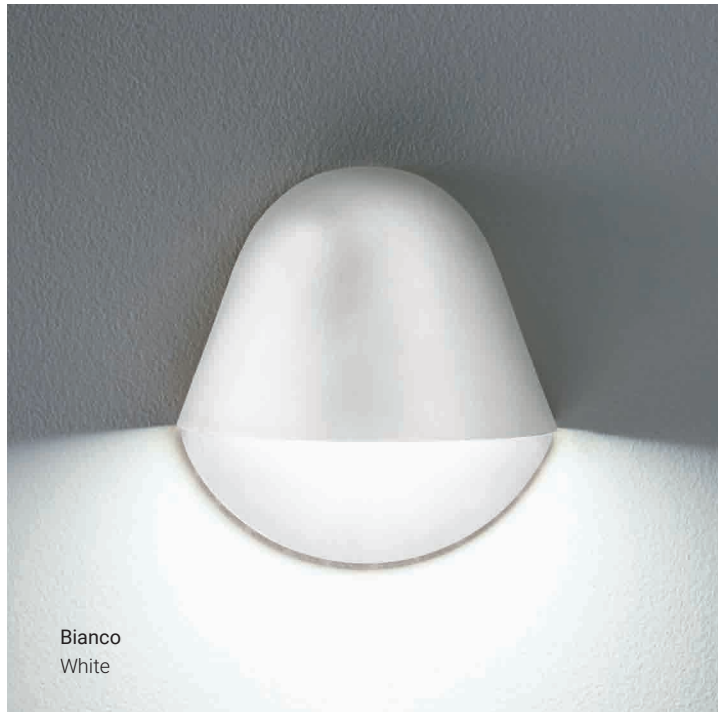
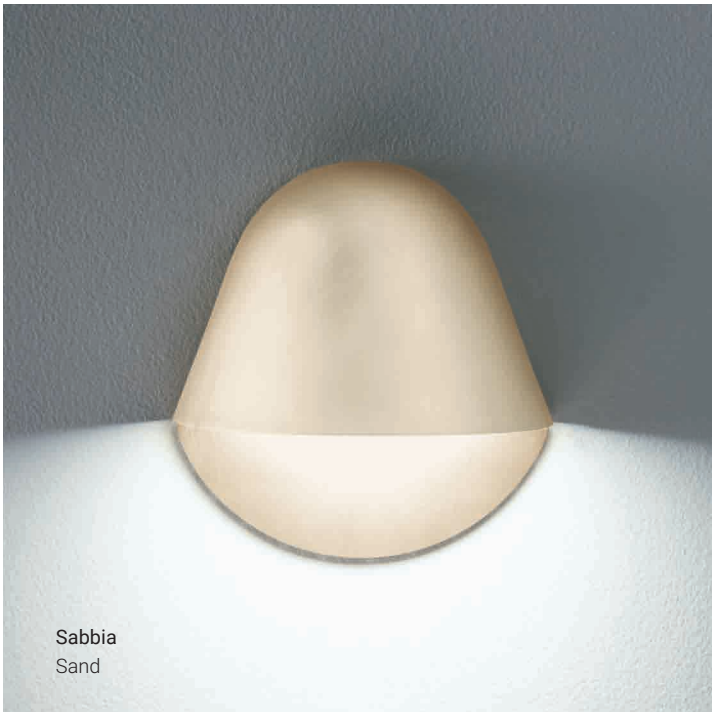

ENOKI *Daniel Debiasi & Federico Sandri, 2017*

1708

Applique realizzata nelle finiture verniciate opache oro, oro rosa, grafite, sabbia e bianco.

Wall lamp in the matt varnished finishes gold, rose gold, graphite, sand and white.

FINITURE OPACHE / MATT FINISHES



Oro
Gold



Sabbia
Sand



Oro rosa
Rose gold



Bianco
White



Grafite
Graphite

SORGENTE / SOURCE

1708-30
10W LED 3000 K - 800 lm
Dimmable Triac

APPLIQUE / WALL

1708-30

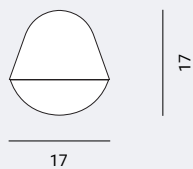

SARA MORONI 2018

F E E L

Light — of silence

Feel nasce dalla combinazione di dischi tessili fonoassorbenti e steli luminosi. I dischi colorati, in tinta o a contrasto tra loro, danno vita a configurazioni sempre diverse, da sospendere al soffitto o fissare a parete per assorbire i rumori e godersi il silenzio.

Feel comes from the combination of sound absorbing textile discs and luminous stems. The coloured discs, in matching or contrasting colours, give life to ever-changing configurations, to be suspended from the ceiling or fixed to the wall, in order to absorb noise and enjoy silence.

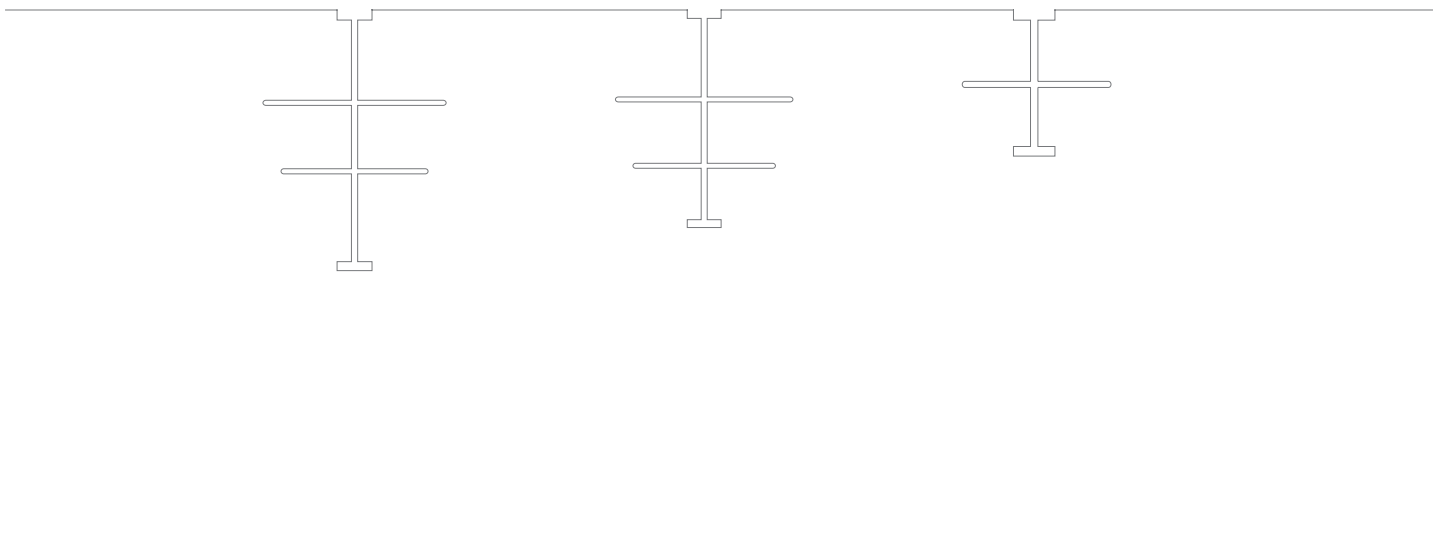





Acoustic solution —









FEEL *Sara Moroni, 2018*

1831

Sospensione modulare con struttura in metallo in tre dimensioni e nelle finiture opache grafite, oro e oro rosa. Dischi in tre diametri, in tessuto fonoassorbente nei colori: bordeaux, blu scuro, petrolio, mattone, sabbia, grigio chiaro, verde scuro. I dischi sono disponibili anche come singolo elemento decorativo, senza luce. Prodotto innovativo che unisce l'illuminazione con la tecnologia della fonoassorbenza. Feel, riducendo il fastidioso riverbero acustico, consente di vivere e lavorare in ambienti meno rumorosi e più confortevoli.

Modular suspension with metal structure in three sizes available graphite, gold and pink gold matt finishes. Sound-absorbing fabric discs are available in three diameters with the following colors: bordeaux, dark blue, petroleum, brick, sand, light grey, dark green. Discs are also available as a single decorative element, without light. Innovative product which mix together lighting and sound proofing technology. Feel, reducing the annoying acoustic reverberation, allows to live and work in quiet and more comfortable spaces.

STRUTTURA METALLO / METAL STRUCTURE

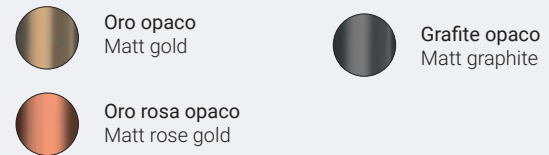

FINITURE TESSUTO / TEXTILE FINISHES



SORGENTE / SOURCE

27W LED 3000 K - 3500 lm 

SOSPENSIONE / SUSPENSION

1831-23
large

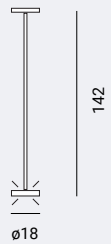

1831-22
medium

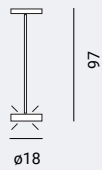

1831-21
mini

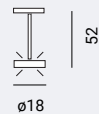

1831-98
medium

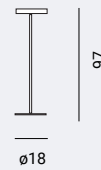

1831-97
mini

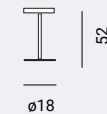

1831-93
large

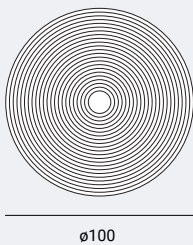

1831-92
medium

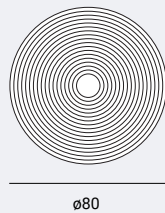

1831-91
mini

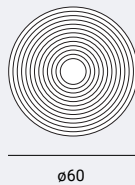

ACCESSORI VERSIONE CIECA / BLIND VERSION ACCESSORIZES





CARLO COLOMBO, 2009-2015

G L O

Glass glares — and reflections

Glo è un'icona della nostra collezione, una sfera di vetro che esalta il riverbero della luce, in un gioco di riflessioni e rimandi tra la lampada e lo spazio o fra le lampade tra loro. La ricca palette e le diverse misure della variante sospesa sono un invito alla composizione.

Glo is an icon of our collection, a glass sphere enhancing the glare of light, in a game of reflections back and forth between the lamp and the space or among the very lamps. The rich palette of colours and the different dimensions of the suspension lamps are a toast to creativity.

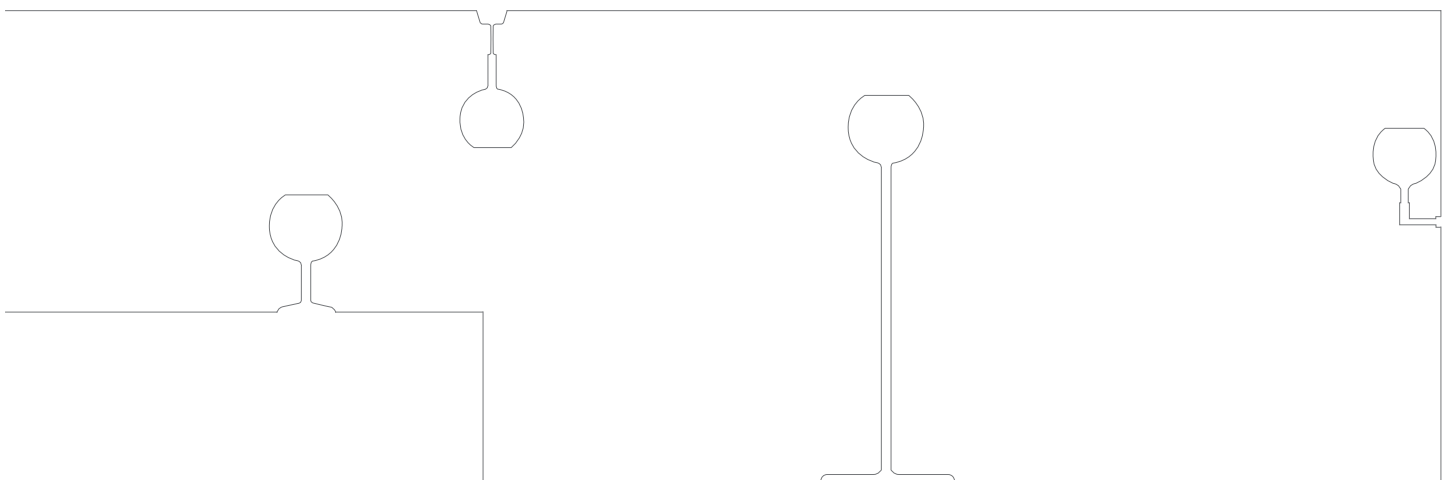





*A glass sphere enhancing
the glare — of light*



Nuovi colori
New colors



Viola
Violet

Verde
Green

Blu
Blue













Argento / Silver

Nera / Black

4 Ever

SPENTA / OFF



Argento / Silver

Nera / Black

4 Ever

ACCESA / ON







Oro rosa
Rose gold















0811

Lampade con struttura in metallo cromato lucido e vetro borosilicato. Diffusore esterno: trasparente, oro, argento, oro rosa, nero, 4ever, blu, verde, viola. Diffusore interno sabbiato. Rosone a soffitto in titanio e bianco.

Lamps with chromed metal structure and borosilicate glass. Outer shade transparent, gold, silver, rose gold, black, 4ever, blue, green, violet. Inner shade sandblasted. Canopy in titanium and white.

TAVOLO / TABLE

0811-03
Large

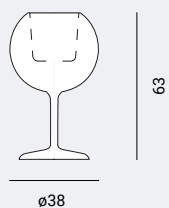

0811-01
Medium

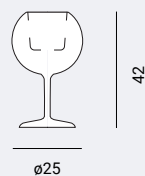

0811-00
Mini

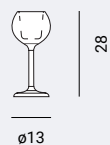

TERRA / FLOOR

0811-10

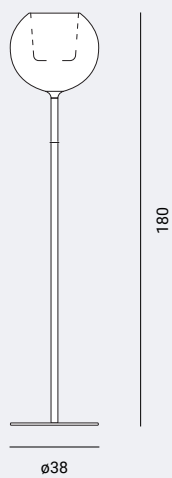

SOSPENSIONE / SUSPENSION

0811-23
Large

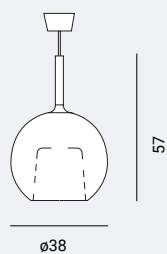

0811-21
Medium

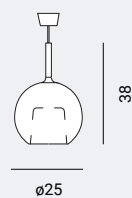

0811-20
Mini

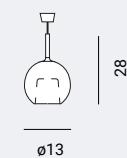

Rosone
canopy

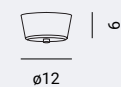

Piastre a pag. 364
plates p. 364

APPLIQUE / WALL LAMP

0811-31
Medium

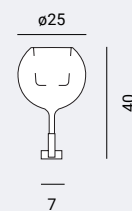

0811-30
Mini

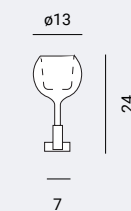

STRUTTURA METALLO APPLIQUES/ METAL STRUCTURE WALL LAMPS



Oro opaco
Matt gold



Grafite opaco
Matt graphite



Oro rosa opaco
Matt rose gold



Bianco opaco
Matt white

STRUTTURA METALLO TERRA/ METAL STRUCTURE FLOOR LAMP



Oro lucido
Glossy gold



Cromo
Chrome

VETRI SPECCHIATI / MIRRORING GLASSES



Trasparente
Transparent



4ever
4ever



Argento
Silver



Blu
Blue



Oro
Gold



Verde
Green



Oro rosa
Rose gold



Viola
Violet



Nero
Black

SORGENTE/ SOURCE 

0811-03
1 x 10W LED E27



0811-23
1 x 10W LED E27

0811-01
1 x 5W LED E14

0811-21
1 x 5W LED E14

0811-00
1 x 3W LED G9

0811-20
1 x 3W LED G9

0811-10
1 x 10W LED E27



0811-30
1 x 3W LED G9

0811-31
1 x 5W LED E14

UMBERTO ASNAGO 2017

JACQUELINE

Light haute couture

Jacqueline è una lampada portatile dall'allure femminile e giocosa che associa tecnologia e sartorialità: i dettagli in pelle sono cuciti a mano e si abbinano al colore dell'alluminio anodizzato della struttura.

Jacqueline is a portable lamp with a feminine playful wit, which combines technology and tailoring: the leather details are hand sewn and match the colour of the anodized aluminium structure.











*Combining technology
— and tailoring*









JACQUELINE *Umberto Asnago, 2017*

1709

Lampada da tavolo portatile e ricaricabile con struttura in metallo spazzolato e cuoio nei seguenti abbinamenti: oro/senape, grafite/antracite, rosa cipria/castagna, blu/blu notte.

Disponibile in due dimensioni: large e small e nella versione per outdoor con protezione IP44.

Portable and rechargeable table lamp with structure in brushed metal and leather in the following matchings: gold/ mustard, graphite/ anthracite, powder pink/ chestnut, blue/ night blue.

Available in two sizes, large and small and in the outdoor version with protection IP44.

METALLO SPAZZOLATO BRUSHED METAL

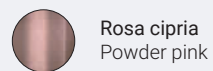
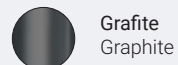

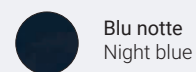
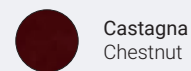

CUOIO LEATHER



SORGENTE/ SOURCE

1709-04
13W LED 3000 K - 1500 lm

1709-03
13W LED 3000 K - 1500 lm 

1709-01
6W LED 3000 K - 600 lm 

TAVOLO / TABLE

1709-04
large

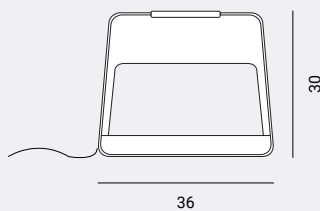

1709-1X
large IP44

1709-03
large rechargeable

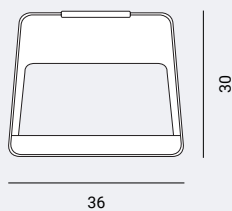

1709-1Y
small IP44

1709-01
small rechargeable



NICOLA GALLIZIA 2005

J E I J E I

A contemporary — chandelier

Reinterpretazione del classico lampadario in vetro, Jei Jei è maestosa ed essenziale. Le canne in vetro borosilicato sottilissimo si innestano nella corona centrale dando vita a composizioni più o meno ricche, anche in versione applique.

Jei Jei is a majestic and essential re-imagining of the classical glass chandelier. The thin borosilicate glass rods engage onto the central crown, giving life to more or less rich compositions, both in the suspension or wall version.

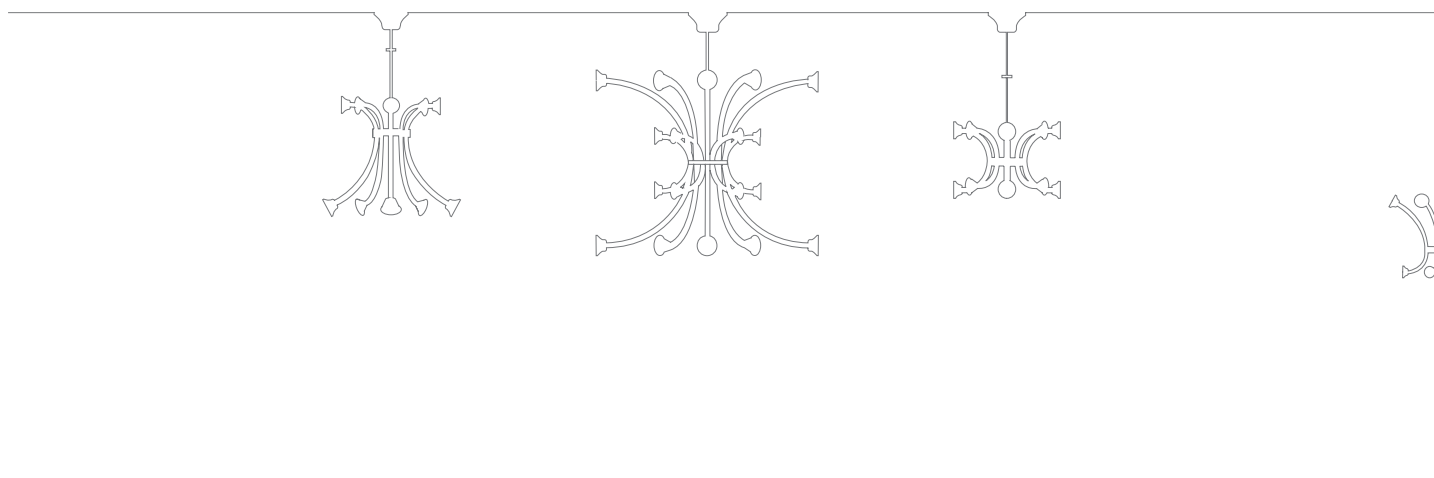



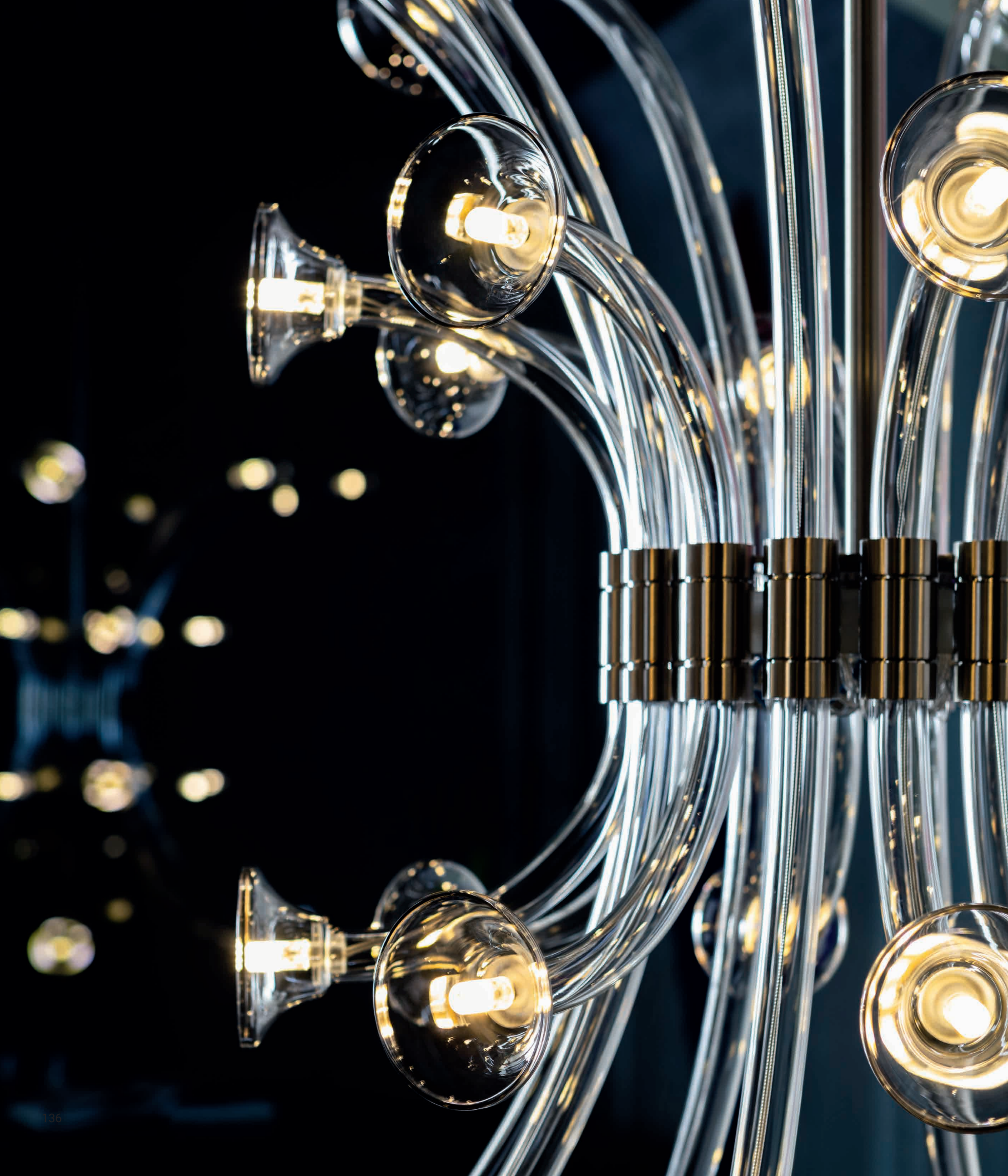





JEI JEI *Nicola Gallizia, 2005*

0501

Lampada sospensione e applique. Struttura in metallo nichel satinato o bronzo con diffusori a braccio modulari grandi, medi e piccoli in vetro borosilicato trasparente (fumé, ambra, oro rosa solo su richiesta)
A richiesta: versione dimmerabile.

Pendant and wall lamps. Structure in nickel satin metal or bronze with modular large, medium and small arm shades in transparent borosilicate glass (fumé, amber or pink gold only on demand).
On demand: dimmerable version.

STRUTTURA IN METALLO / METAL STRUCTURE



Nichel satinato
Nickel satin



Bronzo spazzolato
Brushed bronze

VETRO / GLASS



Trasparente
Transparent



Fumé *
Fumé



Oro rosa *
Rose gold



Ambra *
Amber

* su richiesta / on demand

SORGENTE / SOURCE

2W - 12V - G4 LED

SOSPENSIONE / SUSPENSION

0501-25
supermaxi
48 lights

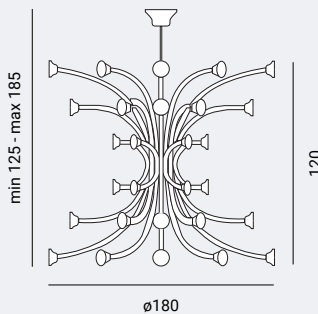

0501-24
maxi
32 lights

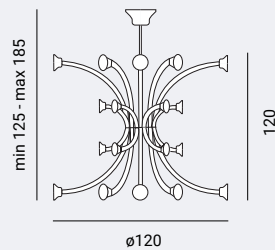

0501-21
small
16 lights

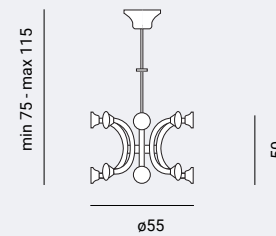

0501-22
medium
16 lights

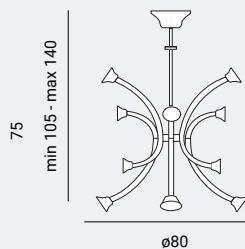
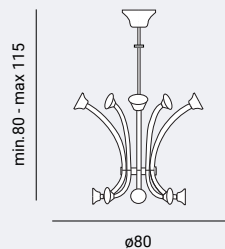
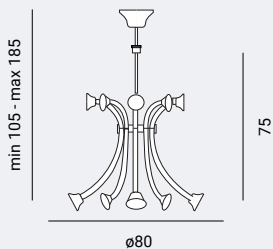

APPLIQUE / WALL

0501-33
large
8 lights

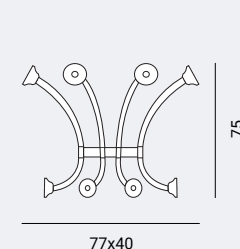

0501-30
small
6 lights

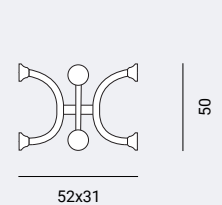

CARLO COLOMBO 2015

J E S U I S

Silvery — full moon

Una lampada scultorea formata da una sfera bicolore in vetro bianco e argento e da un basamento monumentale in marmo di Carrara o legno. Je suis è una dichiarazione d'intenti, tra ricchezza delle finiture e bellezza che supera la funzione.

A sculptural lamp formed by a two-coloured sphere in white and silver glass and by a monumental Carrara marble or wood base. Je suis is a declaration of intents, with its rich finishings and the beauty beyond functionality.

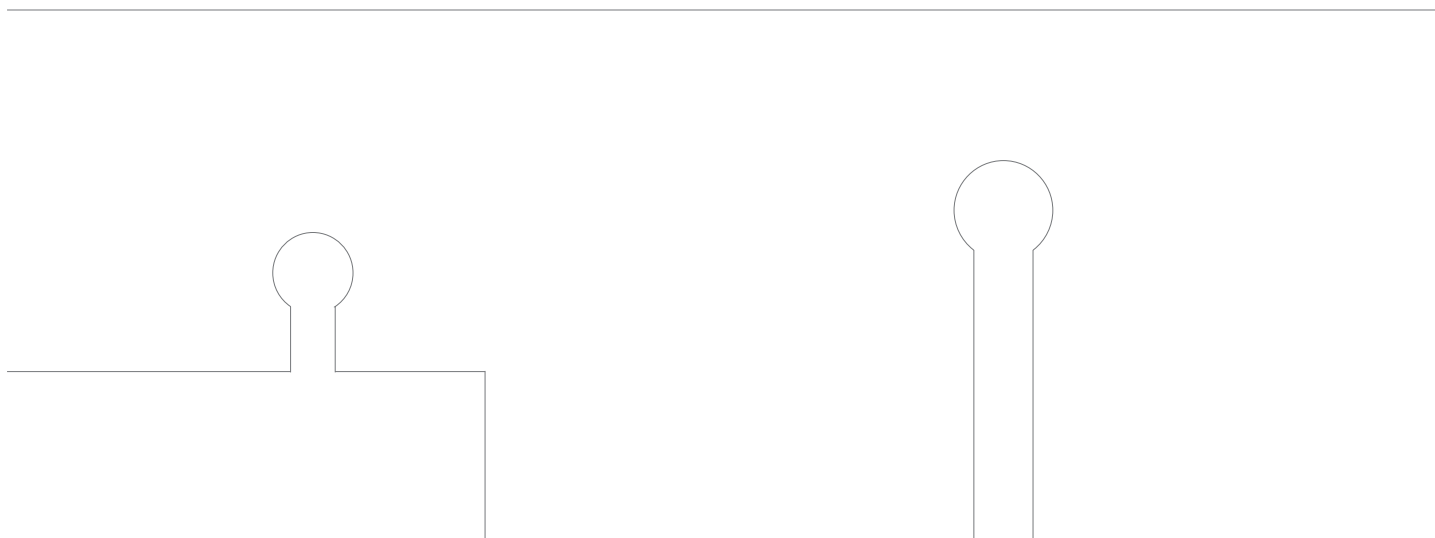













JE SUIS *Carlo Colombo, 2015*

1502

Lampada da terra e tavolo con base realizzata in: legno rovere, rovere grigio, legno tinto antracite o in marmo bianco di Carrara. Diffusore girevole 360° in vetro soffiato bicolore bianco/argento.

Floor and table lamp with base in: oak, grey oak, stained anthracite wood or Carrara white marble. 360° turning bicolor blown glass shade in white/silver.

BASE / BASE



Legno rovere
Oak wood



Legno tinto antracite
Stained anthracite wood



Rovere grigio
Grey oak



Marmo bianco Carrara
White Carrara marble

VETRO / GLASS



Vetro bianco/argento
White silver/glass

SORGENTE / SOURCE

17,5W LED 3000 K



TAVOLO / TABLE

1502-03

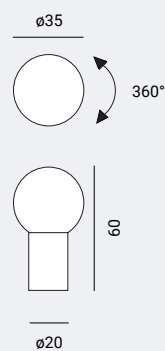

TERRA / FLOOR

1502-10

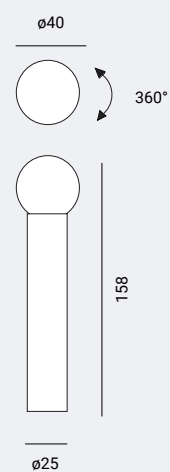

UMBERTO ASNAGO 2015

KLINT

Tradition — meets innovation

Klint è un oggetto scultoreo, un cesto di luce ispirato alla tecnica del vetro a lume della tradizione veneziana. Le canne in tondino di vetro trasparente portano verso l'alto la luce della fonte luminosa a LED.

Klint is a sculptural object, a basket of light inspired by the Venetian lamp-working technique.

The transparent glass rods bring up the light from the actual LED light source.

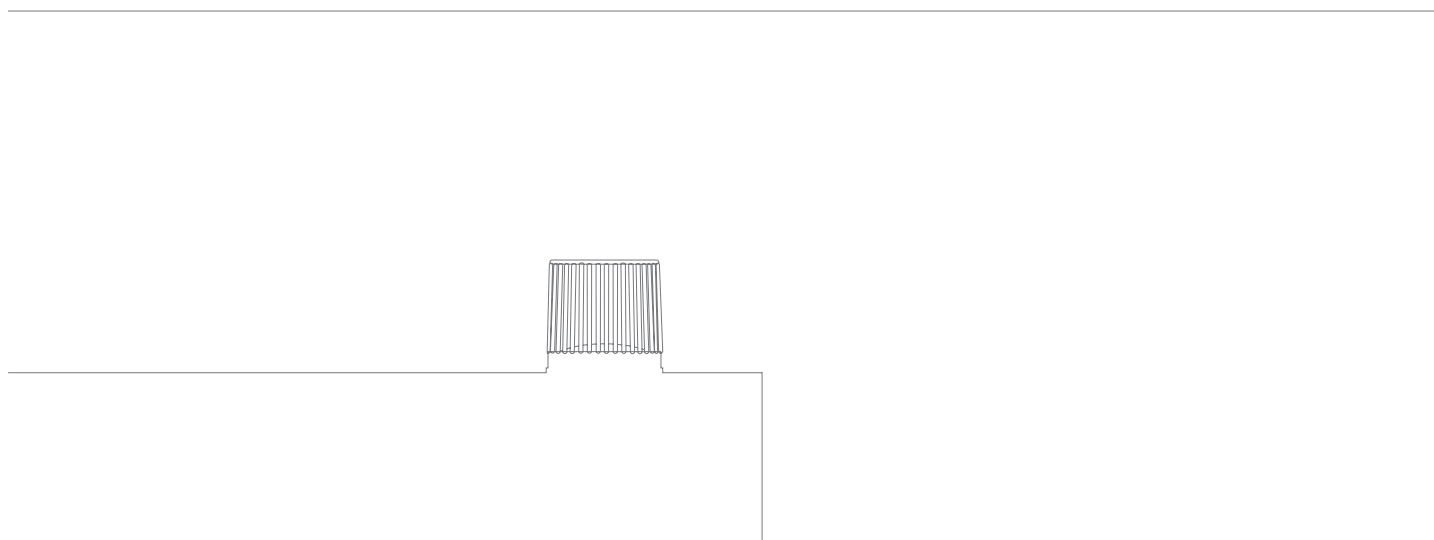

GWATER
LIVING
MEYER CASAS
GG



AND



*A sculptural object
— a basket of light*





KLINT

Umberto Asnago, 2013

1301

Lampade da tavolo realizzate in tondino di vetro trasparente, con base in metallo verniciato grafite. Doppia accensione a led.

Table lamps with structure in transparent glass rod and base in graphite varnished metal. Double led lighting.

STRUTTURA IN METALLO / METAL STRUCTURE

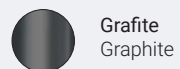

VETRO / GLASS

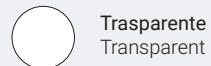

SORGENTE / SOURCE

14W LED 3200 K + 17W LED 3000K

TAVOLO / TABLE

1301-03

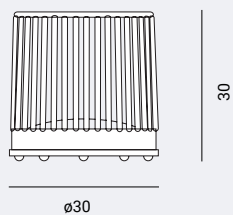

UMBERTO ASNAGO 2018

LAB

Outside — in the nature

Lampada da terra per esterni, Lab è dotata di un dispositivo fotovoltaico per l'autoricarica. Essenziale nelle linee, diffonde una luce indiretta molto calda, in armonia con le ambientazioni più naturali.

Lab is a floor lamp for outdoors, which comes with a solar panel for self charging. With its essential lines, it spreads a very warm indirect light, in perfect harmony with a natural setting.







*In perfect harmony
— with a natural setting*



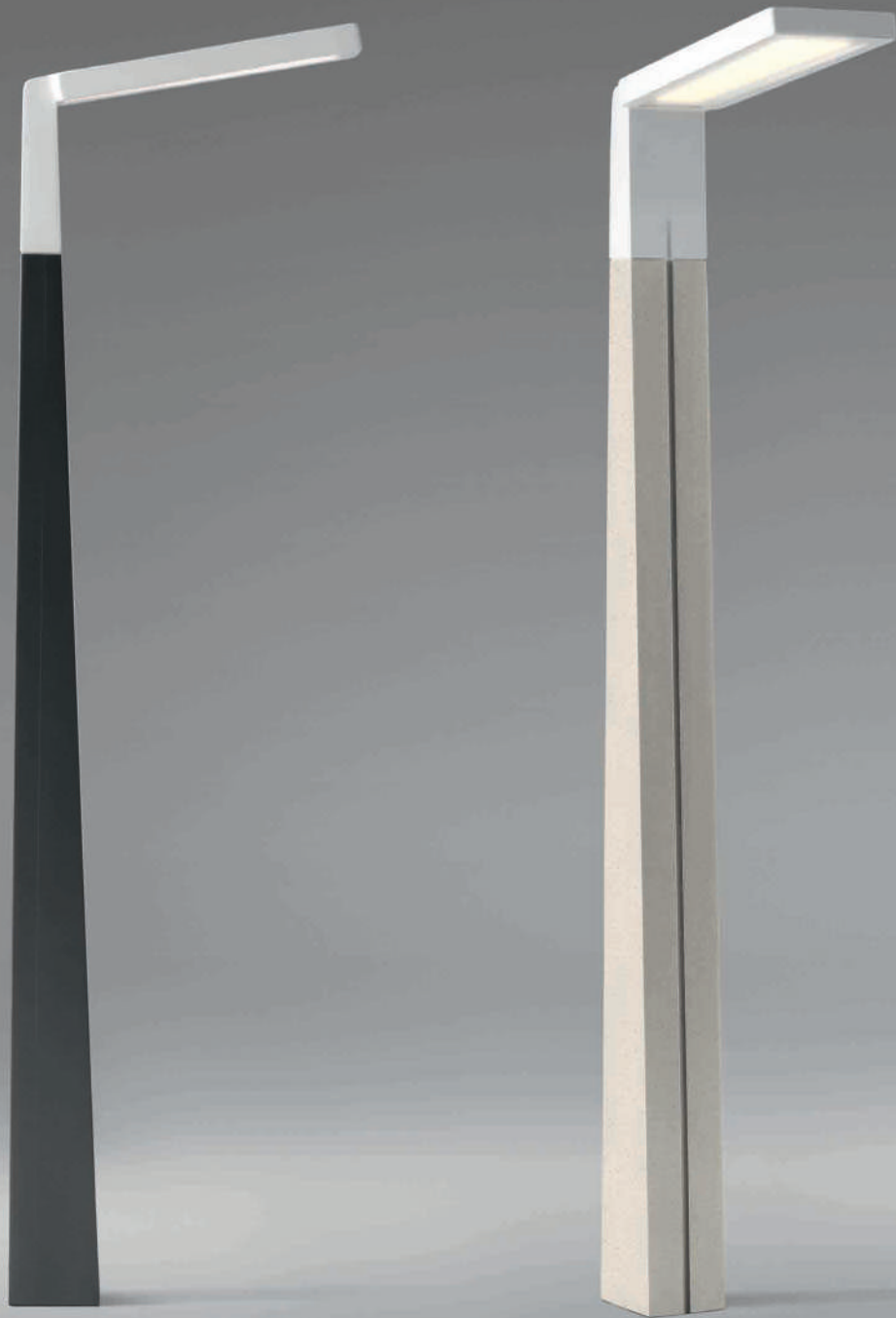



1834

Lampada outdoor da terra con struttura in cemento grigio chiaro o grafite. Diffusore in corian bianco. Disponibile in due dimensioni e due varianti: con alimentazione di rete o con pannello solare per autoricarica. Protezione IP65.

Outdoor floor lamp with structure in light grey or graphite concrete. Diffuser in white corian. Available in two sizes and two variants: with cable power supply or with solar panel for self-charging. IP65 protection.

MATERIALE STELO / STEM MATERIAL

 **Cemento grafite**
Graphite concrete

 **Cemento grigio chiaro**
Light grey concrete

MATERIALE TESTA / HEAD MATERIAL

 **Corian bianco**
White corian

SORGENTE / SOURCE 

1834-1X
3W LED 3000 K - 400 lm

1834-1Y
8W LED 3000 K - 1100 lm

1834-1Z
3W LED 3000 K - 400 lm

1834-1W
8W LED 3000 K - 1100 lm

TERRA / FLOOR

1834-1X
large solar



1834-1Y
large



1834-1Z
small solar

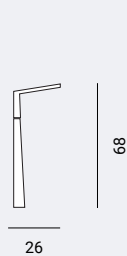

1834-1W
small

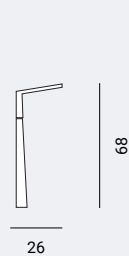

UMBERTO ASNAGO 2019

L I T

Light Inside a Tube

Un oggetto mutevole che cambia con la luce. Spenta, Lit sembra una scultura sospesa, un tubo essenziale reso prezioso dai riflessi che si riverberano sul vetro. Accesa, la lampada rivela un'anima luminosa, calda e gentile.

A mutable object that changes with the light. When off, Lit looks like a suspended sculpture, a minimal tube made precious by the reflections that play on the glass. When lit, the lamp reveals a bright, warm and gentle soul.

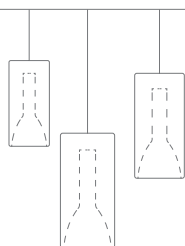







*A mutable object —
that changes with the light.*



SPENTA / OFF



ACCESA / ON



1912

Lampade con struttura in metallo cromato lucido e vetro borosilicato.
Diffusore esterno: viola, blu, oro e arancio. Diffusore interno rigato sabbato. Rosone a soffitto in titanio e bianco.

Suspensions with metal structure and shade in borosilicate glass.
Outer shade in the colors: blue, violet, orange and gold. Inner shade in striped sandblasted glass. Ceiling canopy in white or titanium varnished metal.

DIFFUSORE / OUTER SHADE

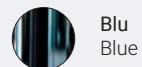

Blu
Blue



Arancio
Orange



Viola
Violet



Oro
Gold

SORGENTE / SOURCE

1912-23
1 x 10W LED E27

1912-22
1 x 10W LED E27

1912-21
1 x 5W LED E14

SOSPENSIONE / SUSPENSION

1912-23
large

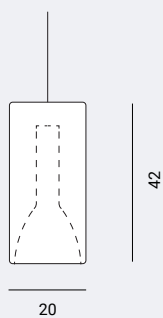

1912-22
medium

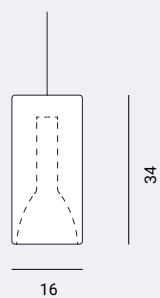

1912-21
small

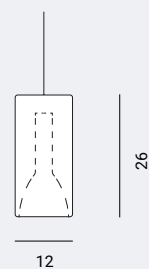

Rosone
Canopy

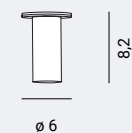

Piastre a pag. 364
plates p. 364



UMBERTO ASNAGO 2015

LULA

A precious — accessory

Un sottile stelo metallico sorregge un corpo illuminante
in vetro dalle linee morbide e femminili.
Nasce così Lula, lampada da tavolo e da terra che decora
lo spazio con eleganza.

A thin metal stem supports a glass lighting body
with soft, feminine lines.

Here is Lula, table or floor lamp that elegantly
decorates the space.

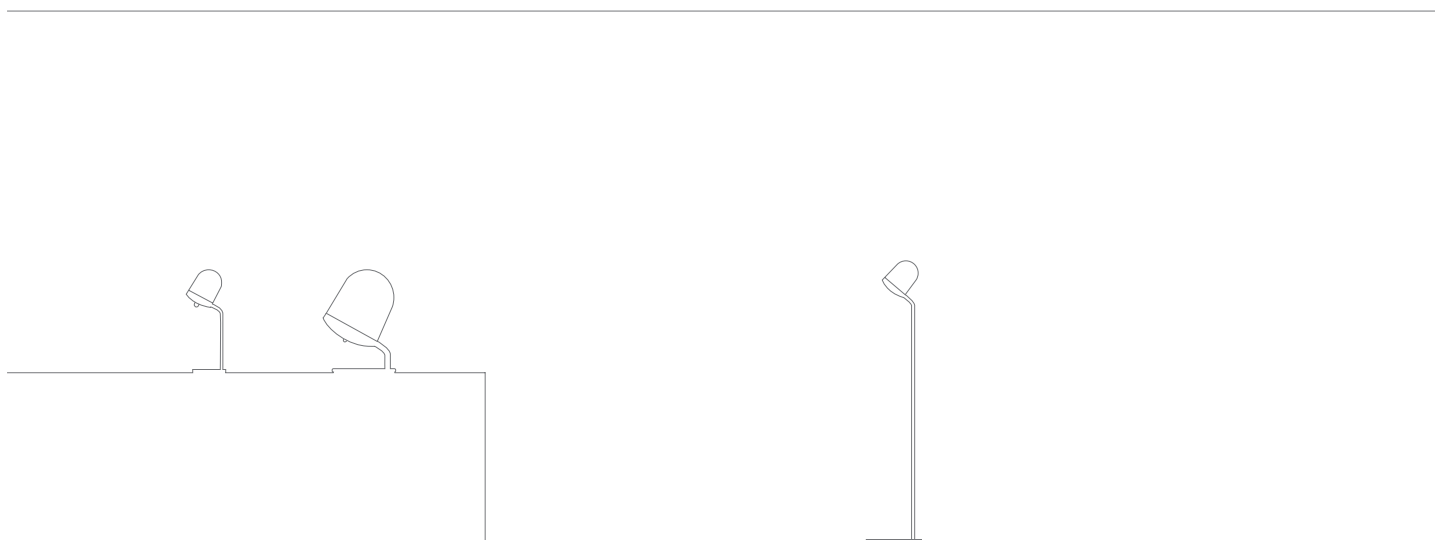

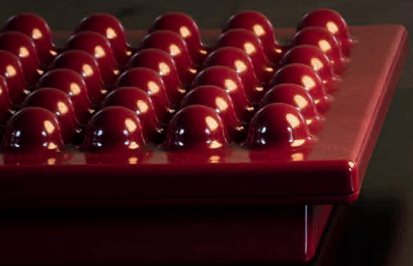

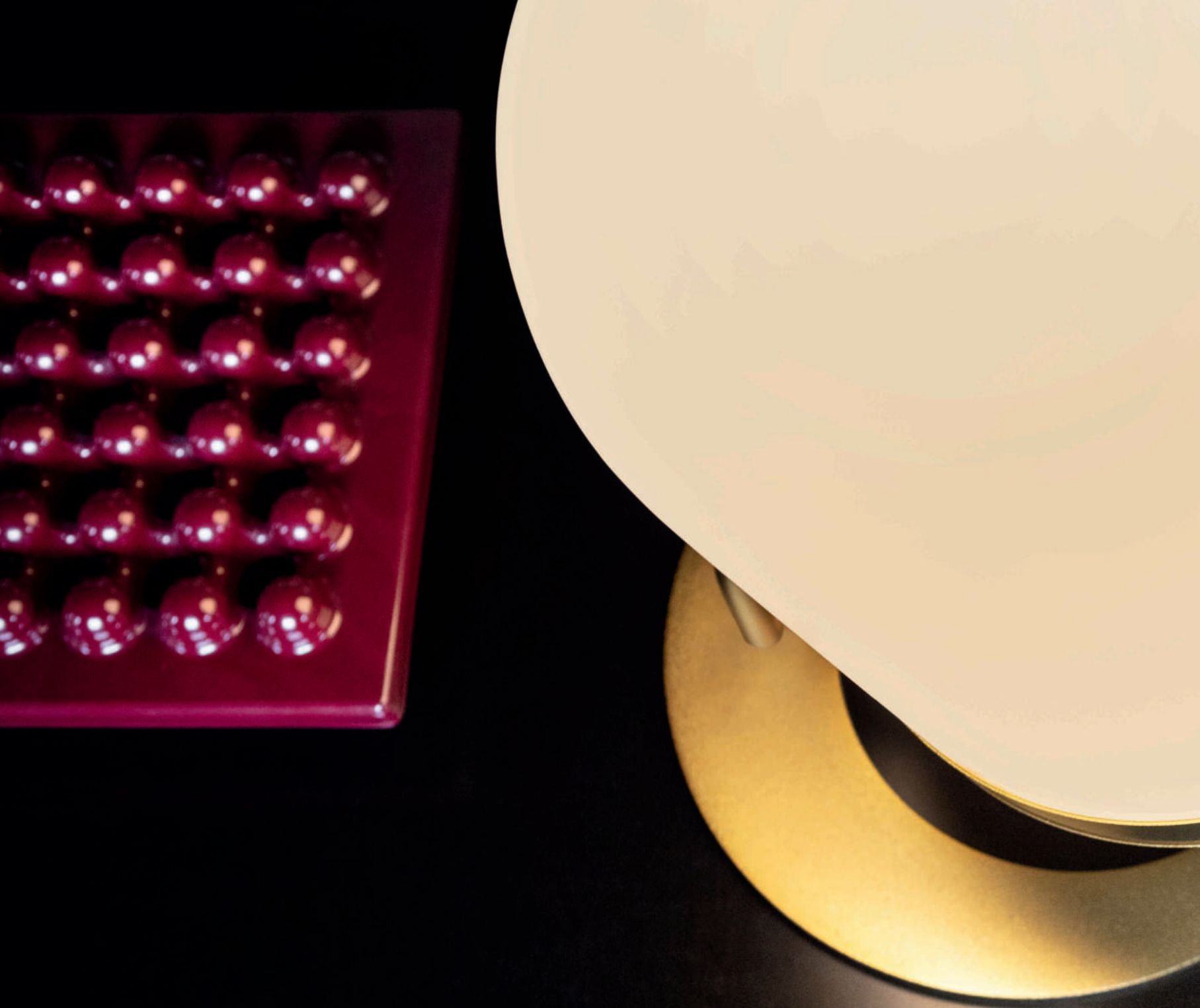

*A glass lighting body
with soft — feminine lines*













LULA *Umberto Asnago, 2015*

1505

Lampade con struttura in metallo nelle finiture verniciate opache oro, oro rosa e grafite. Diffusore in vetro soffiato bianco.

Lamps with matt varnished metal structure in the colours: gold, rose gold and graphite. Shade in blown white glass.

STRUTTURA METALLO / METAL STRUCTURE

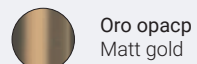

Oro opaco
Matt gold

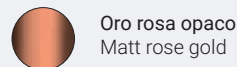

Oro rosa opaco
Matt rose gold

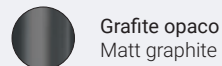

Grafite opaco
Matt graphite

VETRO LUCIDO / GLOSSY GLASS



Bianco
White

SORGENTE / SOURCE

1502-03
1 x 10W LED E27 

1502-02
1 x 5W LED E14

1502-10
1 x 5W LED E14 

TERRA / FLOOR

1505-10

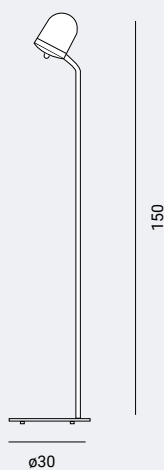

TAVOLO / TABLE

1505-03

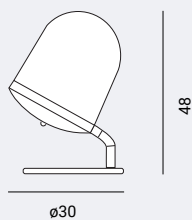

1505-02

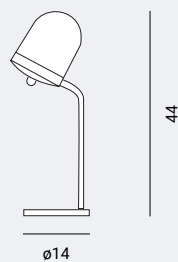

UMBERTO ASNAGO 2015

MAMI

An eclectic — piece of art

Tra design e arte, Mami è una collezione dall'eleganza versatile. Merito del modulo ovale in vetro soffiato bianco, reinterpretato in chiave modernista nelle configurazioni sospese e più lineare nelle varianti da tavolo, da terra e applique.

Halfway between design and art, Mami is a versatile and elegant collection. The white oval blown-glass body is reinterpreted with a modernist look in the suspension compositions, while remaining linear in the floor, table and wall variants.

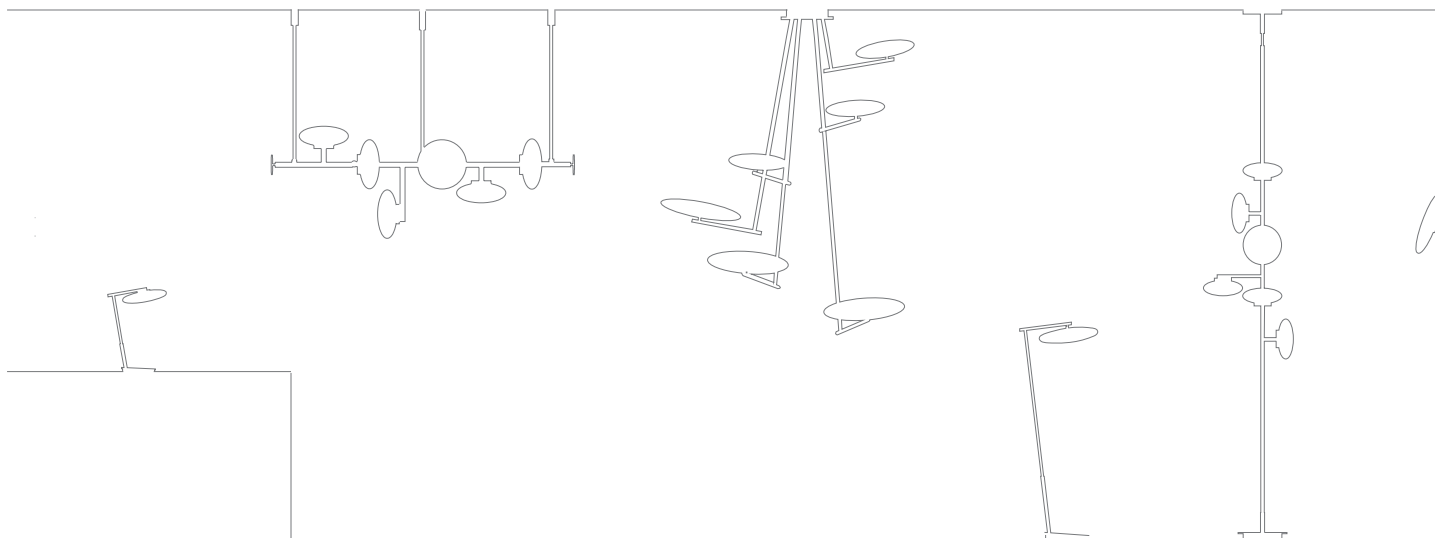











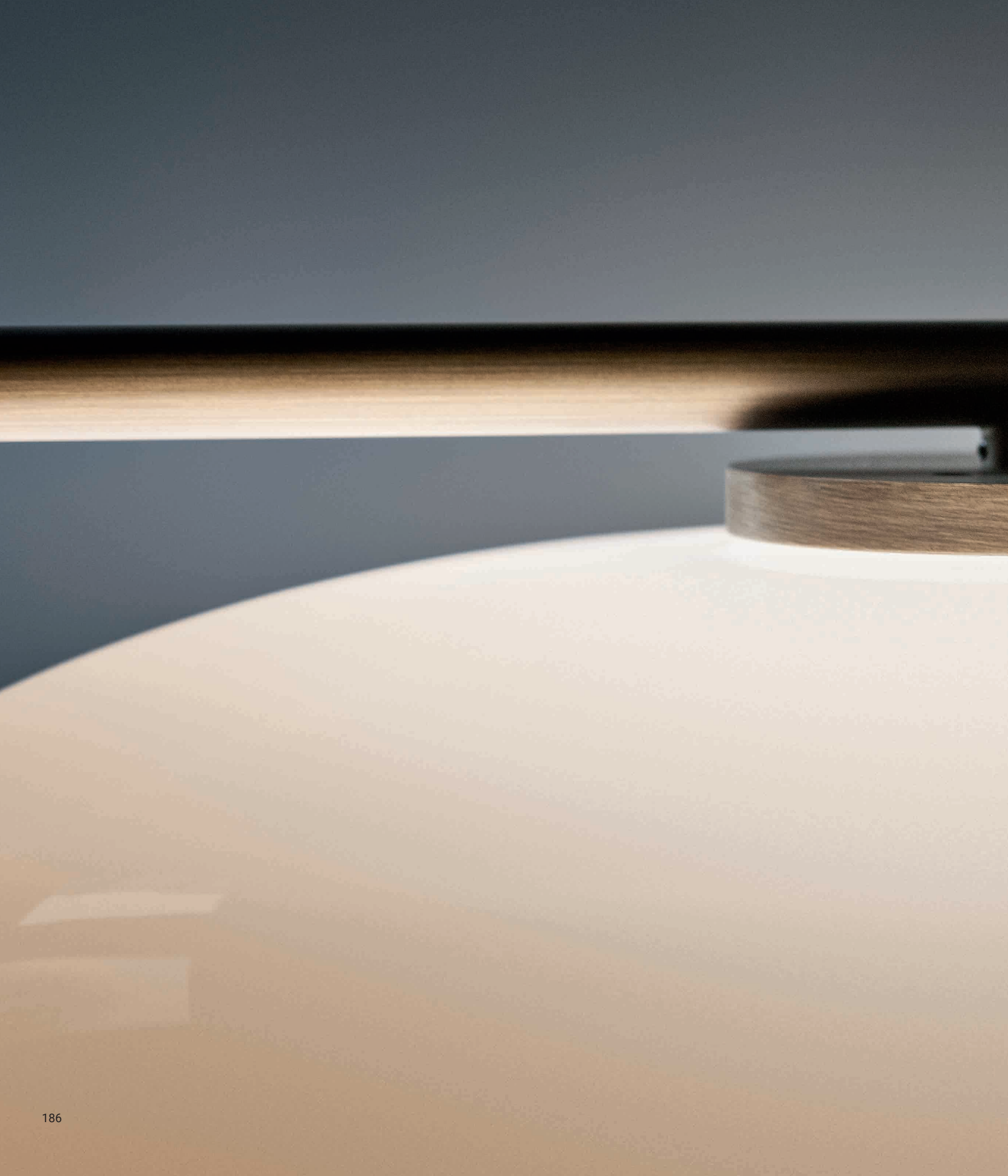

*An elegant collection
halfway between
—design and art*

















Mami orizzontale
Mami orizzontal



Mami verticale
Mami vertical











MAMÌ *Umberto Asnago, 2015*

1307

Lampade con struttura in metallo verniciato grafite o bronzo.
Diffusore in vetro soffiato bianco.

Lamps with structure in graphite varnished metal or bronze.
Shade in white blown glass.

STRUTURA METALLO / METAL STRUCTURE



Bronzo
Bronze



Grafite
Graphite

VETRO LUCIDO / GLOSSY GLASS



Bianco
White

TAVOLO / TABLE

1307-03

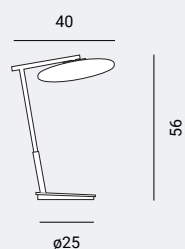

TERRA-CIELO / FLOOR-CEILING

1307-12 large

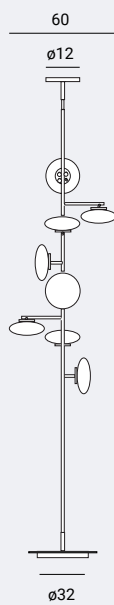

1307-11 small

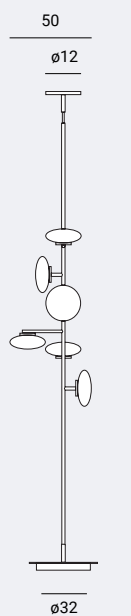

TERRA / FLOOR

1307-10

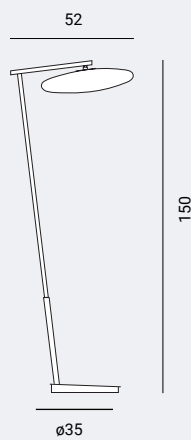

min. 300 - max 270

min. 250 - max 280

APPLIQUE / WALL

1307-33 large



1307-32 medium



1307-31 small



1307-43

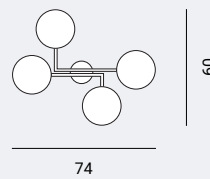

SOSPENSIONI / SUSPENSION

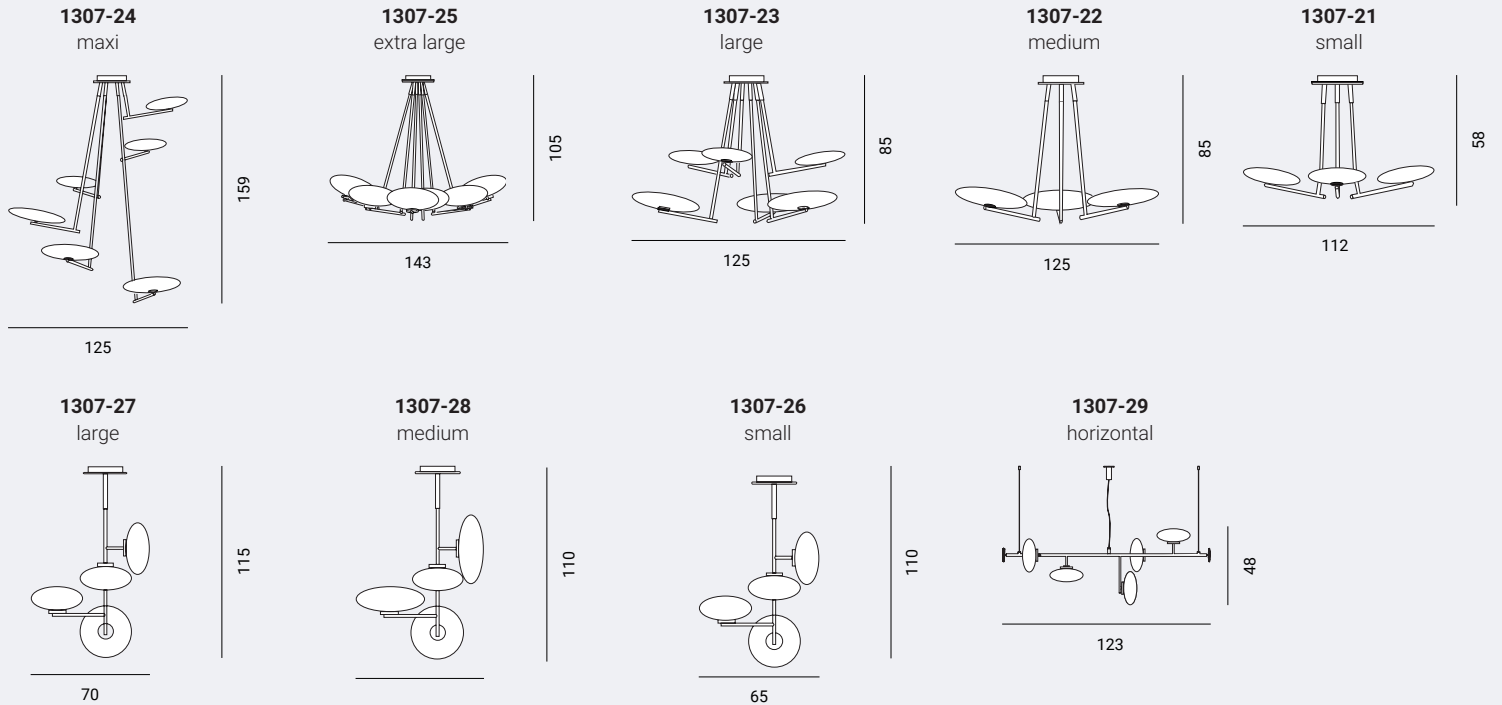

PLAFONIERE / CEILING LAMP

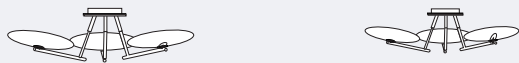

SORGENTE/ SOURCE 

1307-03
10W LED 3000 K

1307-10
10W LED 3000 K

1307-12
8 x 6W LED 3000 K 

1307-11
6 x 6W LED 3000 K 

1307-33
10W LED 3000 K

1307-32
10W LED 3000 K

1307-31
6W LED 3000 K

1307-43
4 x 6W LED 3000 K

1307-24
6 x 10W LED 3000 K

1307-25
6 x 10W LED 3000 K

1307-23
6 x 10W LED 3000 K

1307-22
3 x 10W LED 3000 K

1307-21
3 x 10W LED 3000 K

1307-27
4 x 10W LED 3000 K

1307-28
2x 10W LED 3000 K + 2 x 6 W LED 3000 K

1307-26
4 x 6W LED 3000 K

1307-29
5 x 6W LED 3000 K

1307-42
3 x 10W LED 3000 K

1307-41
3 x 10W LED 3000 K

UMBERTO ASNAGO 2016

M O M

Venetian heritage — for today

Sono ispirate alla tradizione veneziana le lampade Mom, che nella forma e nelle finiture opache si rifanno ai classici vasi in vetro di Murano. Disponibili anche nelle varianti da tavolo e applique, in versione lucida sono simili a pietre preziose.

Mom lamps are inspired by the Venetian tradition, and refer, in the shape and opaque finishings, to the classical Murano glass vases. Also available in table and wall variants, in the glossy variants they look like precious stones.











*Inspired by —
the Venetian tradition*





Verde salvia
Sage green

Rosa cipria
Powder pink

Senape
Mustard

Sabbia
Sand

Blu avio
Blue avio



Nero
Black

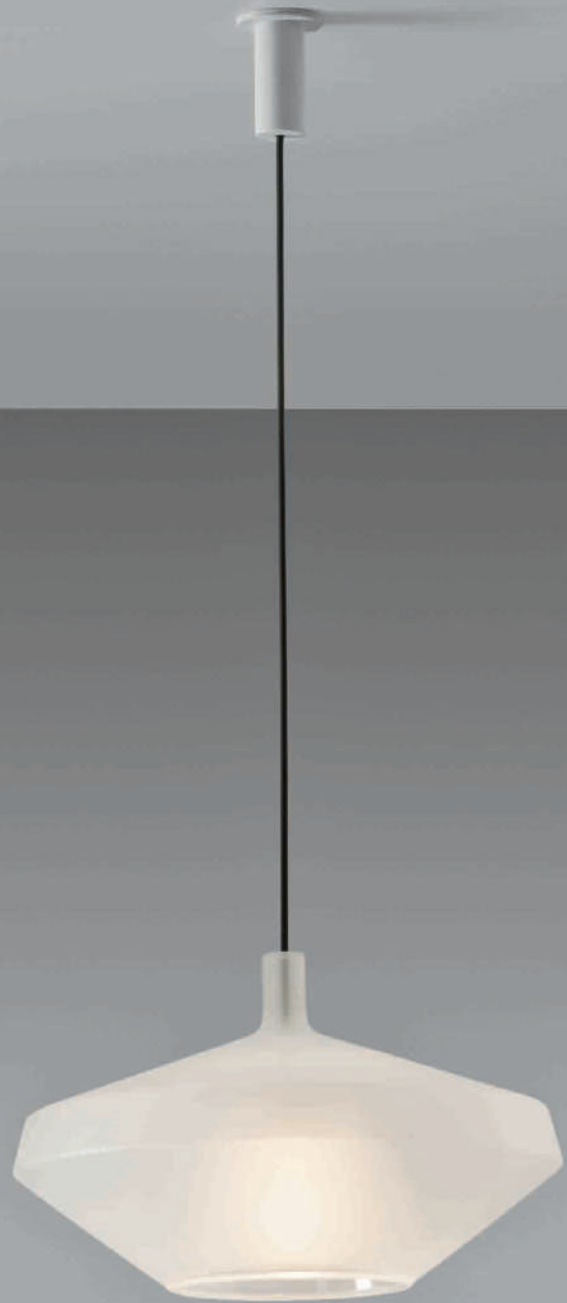

Bianco
White

Colori opachi
Matt colors





Viola lucido
Glossy violet

SPENTA / OFF



Blu lucido
Glossy blue



Verde lucido
Glossy green



ACCESA / ON















MOM *Umberto Asnago, 2016*

1602

Collezione di lampade in cinque forme realizzate in vetro borosilicato
 Finitura opaca: senape, blu avio, verde salvia, rosa cipria, sabbia,
 bianco e nero. Finitura lucida: blu, verde, viola. Lampade da tavolo con
 struttura in metallo nei colori opachi oro, oro rosa e grafite. Appliques
 con struttura in metallo nei colori opachi oro, oro rosa, grafite e bianco.
 Rosone a soffitto bianco o titanio.

Collection of lamps in five shapes made in borosilicate glass: Mat
 finishes: blue avio, sage green, powder pink, sand, white. Glossy finishes:
 green, blue, violet. Table lamps with metal structure in the colors gold,
 rose gold and graphite. Wall lamps in the colors gold, rose gold, graphite
 and white. Canopy in white or titanium varnished metal.

SOSPENSIONE / SUSPENSION

1602-21
low

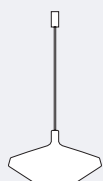

1602-22
tall



1602-23
slim



1602-24
fatty

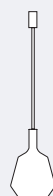

1602-25
little



Rosone
Canopy

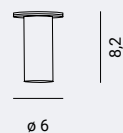

Piastre a pag. 364
plates p. 364

TAVOLO / TABLE

1602-01
low

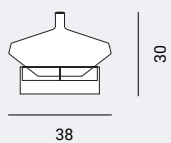

1602-02
tall

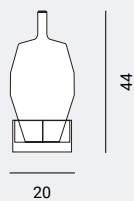

1602-04
fatty

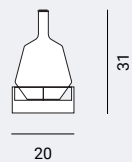

1602-05
little

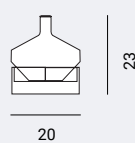

APPLIQUE / WALL

1602-34
fatty

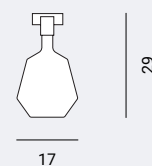

1602-33
slim

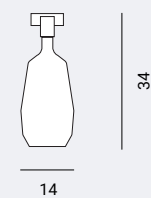

VETRI FINITURE OPACHE / MATT GLASSES FINISHES



VETRI FINITURE LUCIDE / GLOSSY GLASSES FINISHES

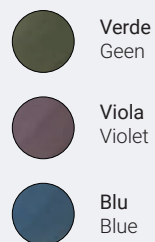

STRUTTURA TAVOLO / TABLE STRUCTURE



STRUTTURA APPLIQUE / WALL STRUCTURE

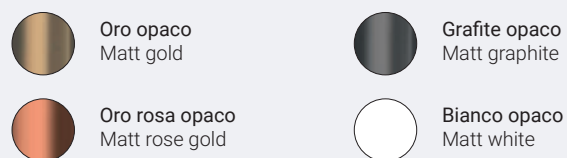

SORGENTE/ SOURCE

1602-21
1 x 10W LED E27

1602-22
1 x 10W LED E27

1602-23
1 x 10W LED E27

1602-24
1 x 5W LED E14

1602-25
1 x 5W LED E14

1602-01
1 x 10W LED E27

1602-02
1 x 10W LED E27

1602-04
1 x 5W LED E14

1602-05
1 x 5W LED E14

1602-33
1 x 5W LED E14

1602-34
1 x 5W LED E14





NICOLA GALLIZIA 2017

NARCISO

Inspired by — an eternal myth

Come nel mito classico Narciso guarda la sua immagine riflessa nell'acqua, così il cono dell'omonima lampada si sdoppia per diffondere e riflettere la luce delicata del corpo illuminante. Omaggio alla musica la versione da tavolo, con diffusore audio bluetooth.

As in the classic myth Narciso looks at his image reflected in the water, likewise the cone of this lamp splits up to spread and reflect the delicate light of the lighting body. The table version is a tribute to music, complete with bluetooth audio speakers.

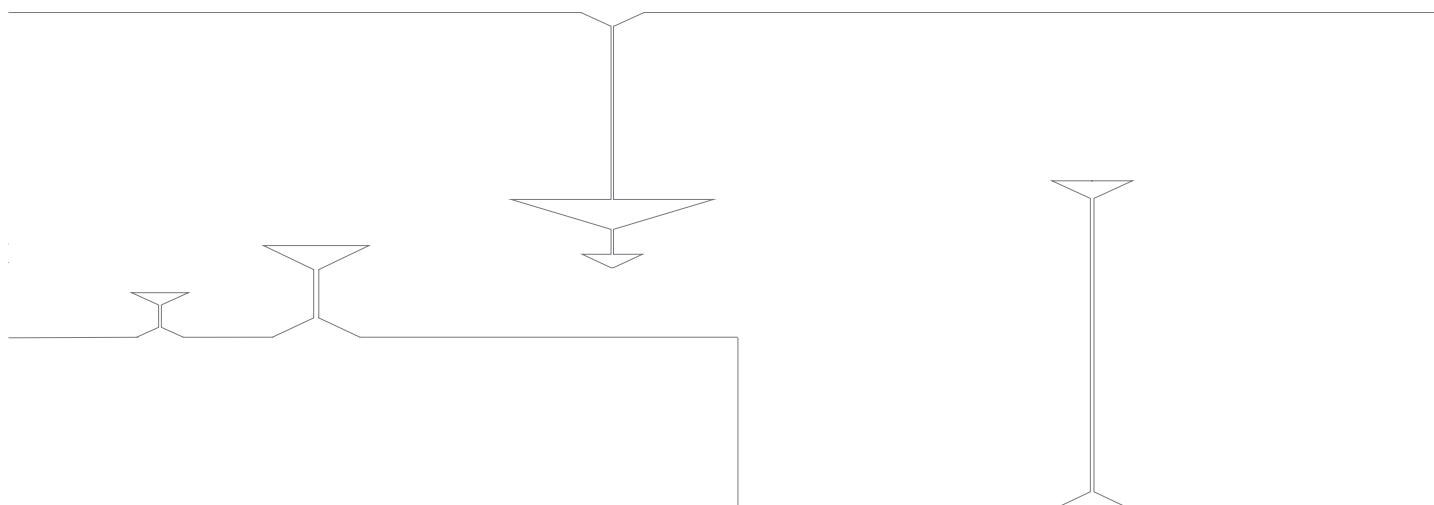







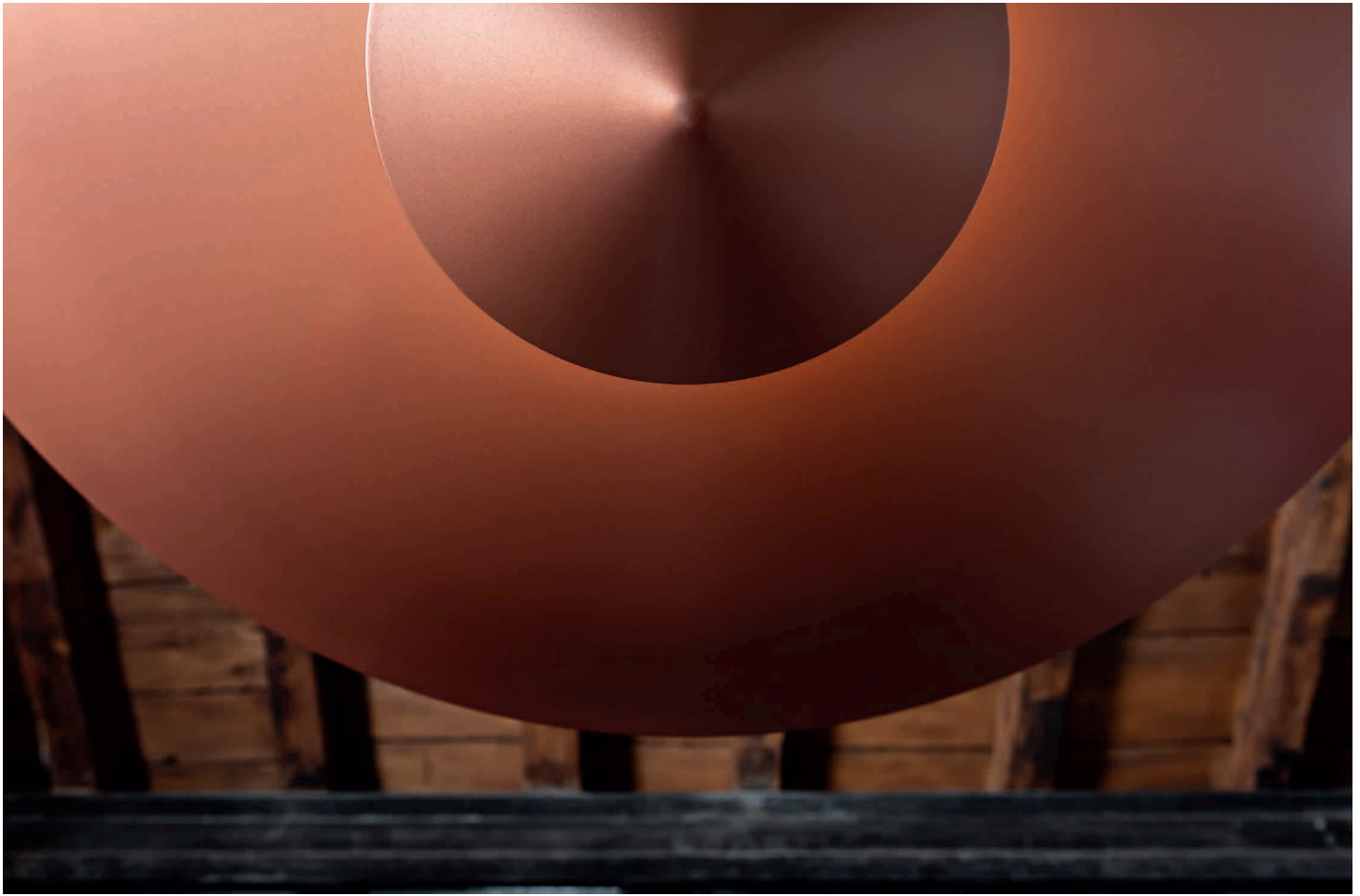





A close-up photograph of a thin, curved metal blade, possibly a scalpel or a specialized surgical instrument, set against a dark background with vertical light streaks. The blade is positioned in the lower-left quadrant, curving towards the right. The lighting is dramatic, highlighting the sharp edge and the smooth, reflective surface of the metal. The background consists of several vertical, parallel light streaks that create a sense of depth and texture.

*Splitting up to spread —
and reflect the delicate light*

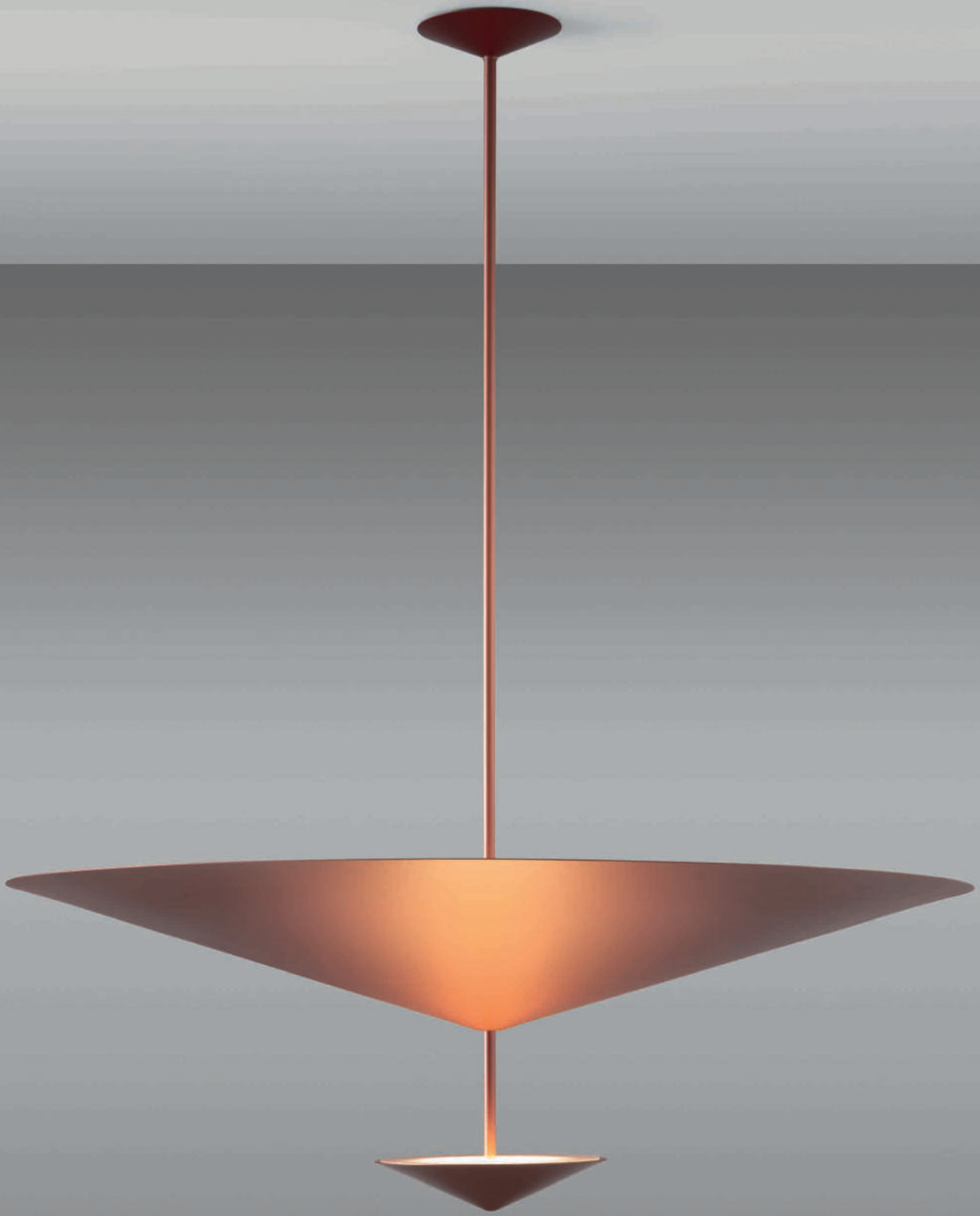

















NARCISO *Nicola Gallizia, 2017*

1710

Lampade con struttura in metallo nelle finiture: oro opaco, oro rosa opaco, grafite opaco e verniciato bianco. La lampada da tavolo piccola è portatile, dotata di batteria ricaricabile. La lampada da tavolo grande è disponibile nella versione portatile/ricaricabile con diffusore audio bluetooth. A richiesta: sospensione dimmerabile. Disponibile anche nella versione outdoor con protezione IP44.

Lamps with metal structure in the finishes: mat gold, mat pink gold, mat graphite and white varnished. The small table lamp is portable, with rechargeable battery. The large table lamp is available in the portable/rechargeable version with Bluetooth audio speaker. On demand: dimmable pendant. Available also as outdoor version with protection IP44.

STRUTTURA METALLO / METAL STRUCTURE

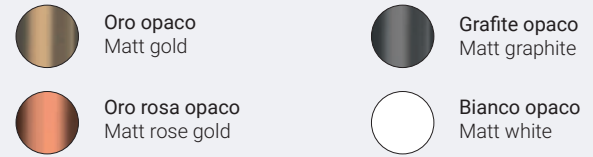

SORGENTE / SOURCE

1710-03
14W LED 3000 K - 1500 lm

1710-04
8W LED 3000 K - 1000 lm

1710-01
4,5W LED 3000 K - 450 lm

1710-10
4,5W LED 3000 K - 450 lm

1710-15
14W LED 3000 K - 1500 lm

1710-20
14W LED 3000 K - 2600 lm
+
45W LED 3000 K - 6000 lm

TAVOLO / TABLE

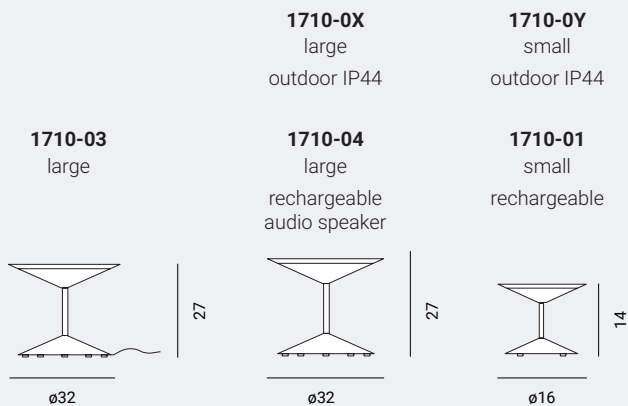

SOSPENSIONE / SUSPENSION

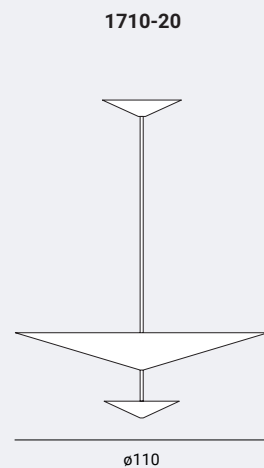

TERRA / FLOOR

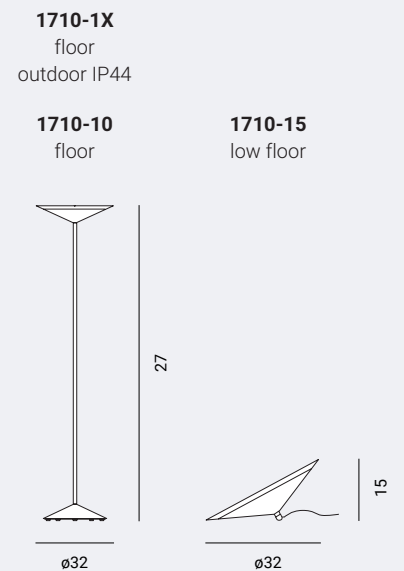

UMBERTO ASNAGO 2011

P O L A R

An iceberg of — warm light

Polar è un volume puro di vetro soffiato opalino che diffonde un chiarore caldo e morbido. Un totem di luce che rende subito accogliente qualsiasi spazio.

Polar is a pure volume of opal blown glass which spreads a warm and soft glow. A light totem, designed to immediately put warmth in any place.

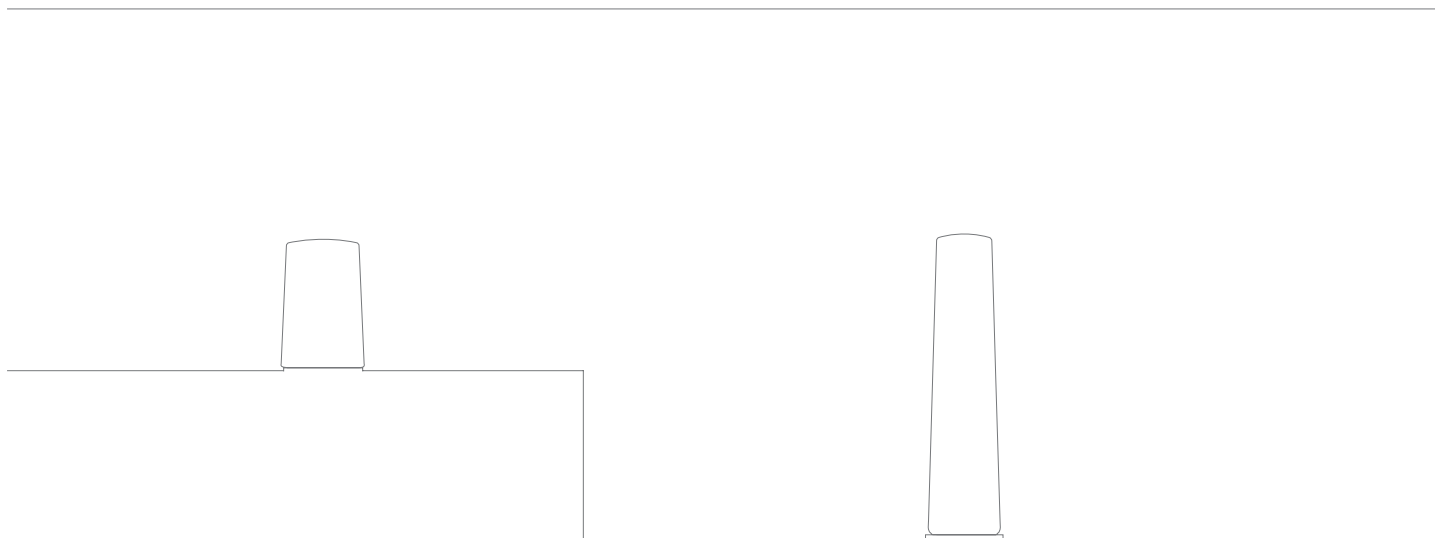



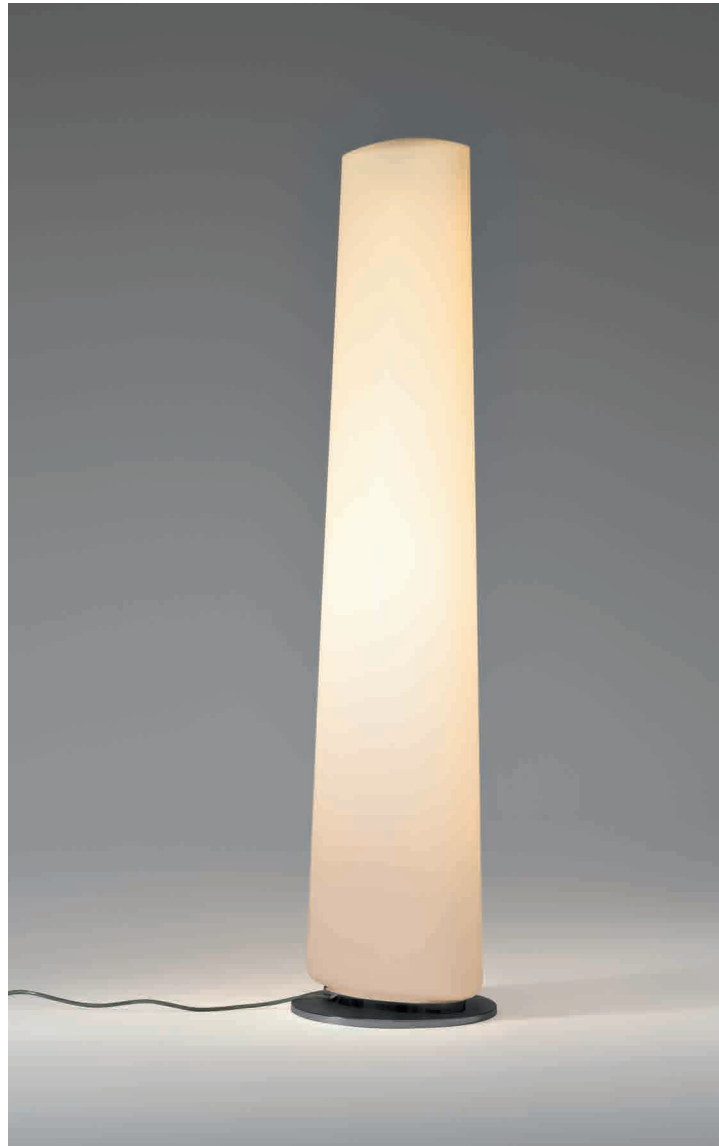





POLAR *Umberto Asnago, 2011*

1106

Lampade da terra e tavolo con struttura in metallo verniciato grafite.
Diffusore in vetro soffiato opalino bianco.

Floor and table lamps with structure in graphite varnished metal.
Shade in white opal blown glass.

STRUTTURA METALLO / METAL STRUCTURE

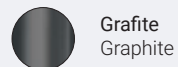

FINITURA DIFFUSORE / SHADE FINISHES

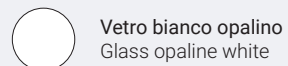

SORGENTE / SOURCE

1106-03
28,8W LED 2700 K



110610
58W LED 2700 K



TERRA / FLOOR

1106-10

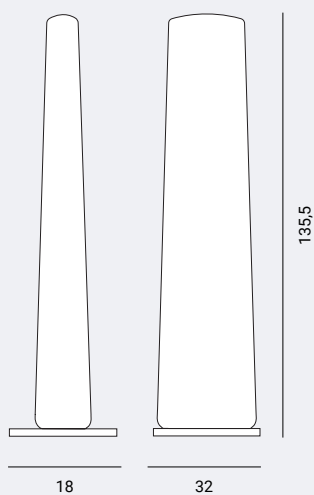

TAVOLO / TABLE

1106-03

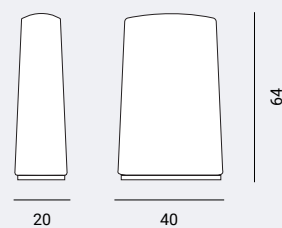

UMBERTO ASNAGO 2017

POP

Light vs. shade

Una lampada dalle forme giocose, un oggetto indisciplinato che mescola ironia ed eleganza: Pop è un applique sferica che dipinge sulla parete luci e ombre inattese.

A playful lamp, an unruly object that mixes irony and elegance: Pop is a spherical wall light that paints unexpected lights and shadows on the wall.





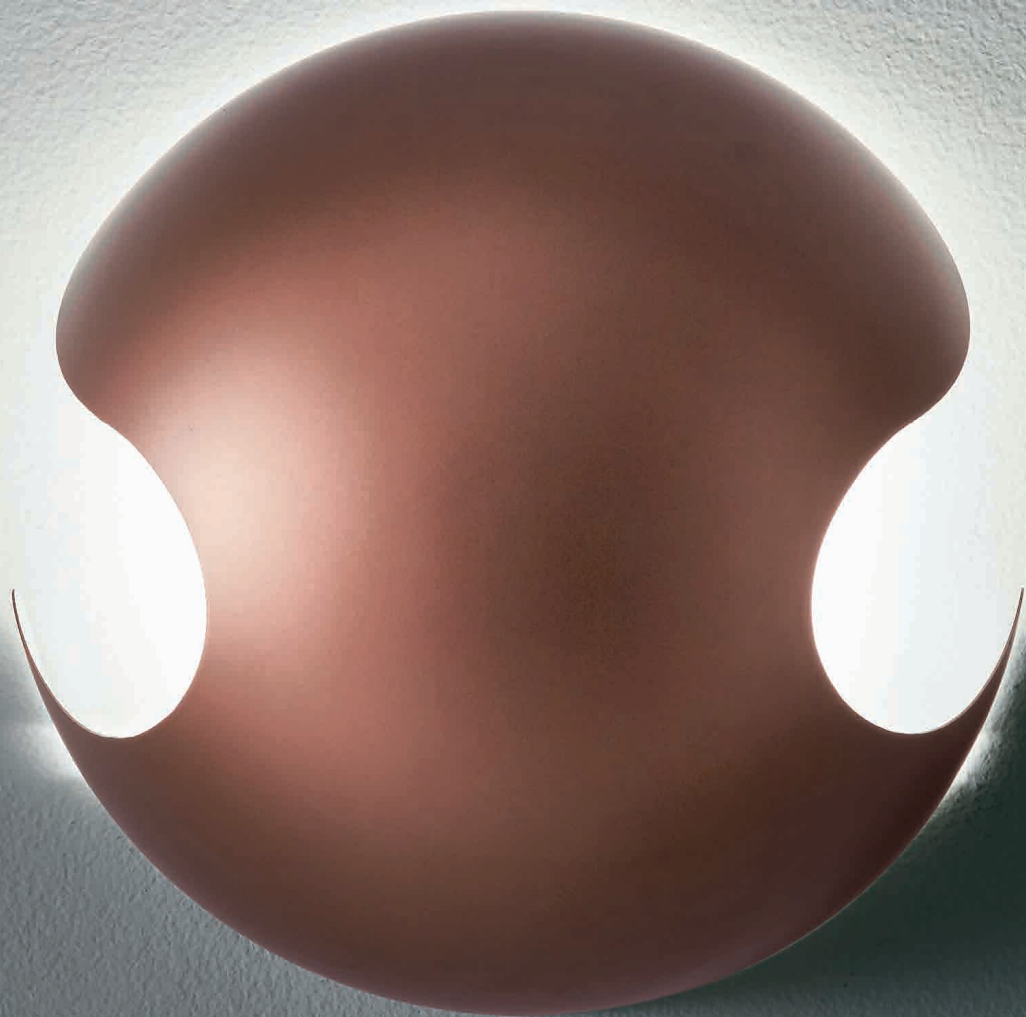



*A playful lamp —
an unruly object*

POP *Umberto Asnago, 2017*

1705

Applique orientabile nelle finiture lucide o opache: oro, oro rosa, grafite, sabbia e bianco.

Adjustable wall lamp in the glossy or matt finishes: gold, rose gold, graphite, sand and white.

FINITURE LUCIDE O OPACHE / GLOSSY OR MAT FINISHES



Oro
Gold



Sabbia
Sand



Oro rosa
Rose gold



Bianco
White



Grafite
Graphite

SORGENTE / SOURCE

1705-30
10W LED 3000 K - 1300 lm
Dimmable Triac

APPLIQUE / WALL

1705-30

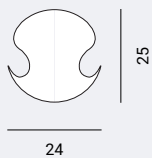

UMBERTO ASNAGO 2017

S P O O N

Beauty — matches function

L'estrema pulizia della forma incontra la ricchezza della pelle intrecciata nella collezione Spoon, un piccolo capolavoro di bellezza e funzionalità, con stelo e calotta da orientare a piacere.

An extreme neat shape meets the rich hand woven leather in Spoon collection, a small masterpiece of beauty and functionality, with swiveling stem and shell.









*A small masterpiece
— of beauty
and functionality*















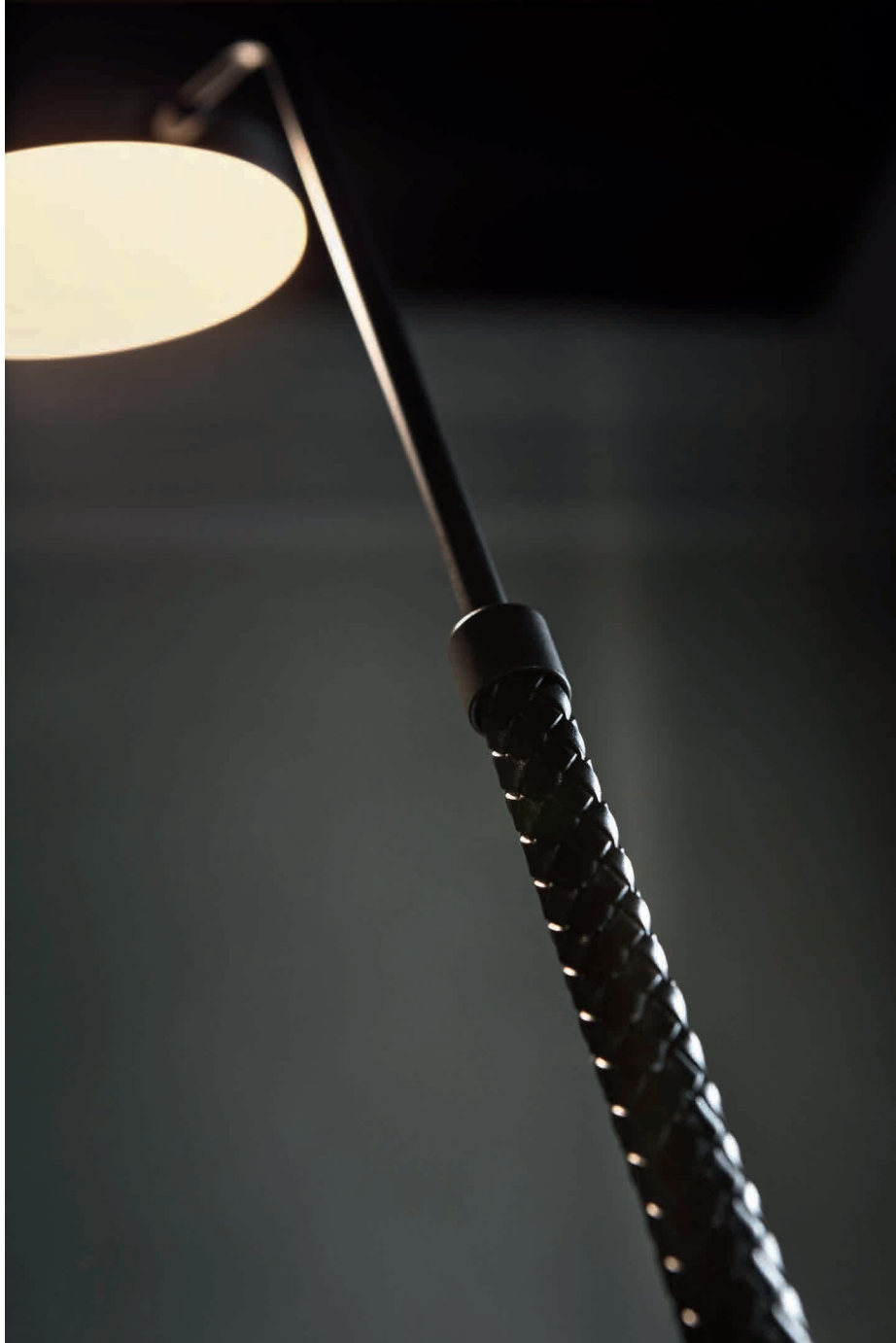







SPOON *Umberto Asnago, 2017*

1706

Lampade con struttura in metallo opaco e pelle intrecciata a mano nei seguenti abbinamenti: oro rosa opaco / pelle cognac e grafite opaco / pelle nera. Rosone singolo nelle stesse finiture della struttura. Utilizzabile come elemento singolo o multiplo.

Lamps with structure in mat metal and hand-woven leather in the following matchings: matt pink gold / cognac leather and matt graphite / black leather. Single canopy in the same finishes of the structure. Available as single element or in cluster.

FINITURE / FINISHES



Oro rosa opaco
Matt rose gold



Pelle cognac
Cognac leather



Grafite opaco
Matt graphite



Pelle nera
Black leather

SORGENTE / SOURCE

1706-21

2x4W LED 3000 K - 2x600 lm

4W LED 3000 K - 600 lm

TAVOLO / TABLE

1706-00

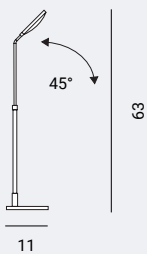

TERRA / FLOOR

1706-10

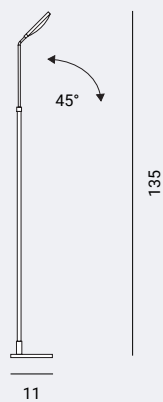

SOSPENSIONE / SUSPENSION

1706-21

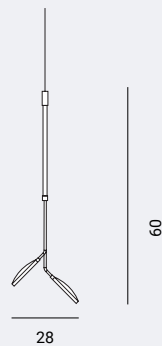

APPLIQUE / WALL

1706-30

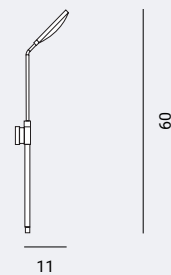

BARTOLI DESIGN 2017

STORM

Lights — that sparkle

Steli sottili in preziose finiture metalliche creano suggestive armonie di luce. Disponibile in tre misure, Storm è una lampada che vive anche da sola ma è pensata per essere usata in gruppo, negli spazi del contract come in quelli di casa.

Thin stems in precious metallic finishes create evocative harmonies of light. Available in three sizes, Storm is a lamp that can live alone but is designed to be used in groups, in public spaces as well as at home.

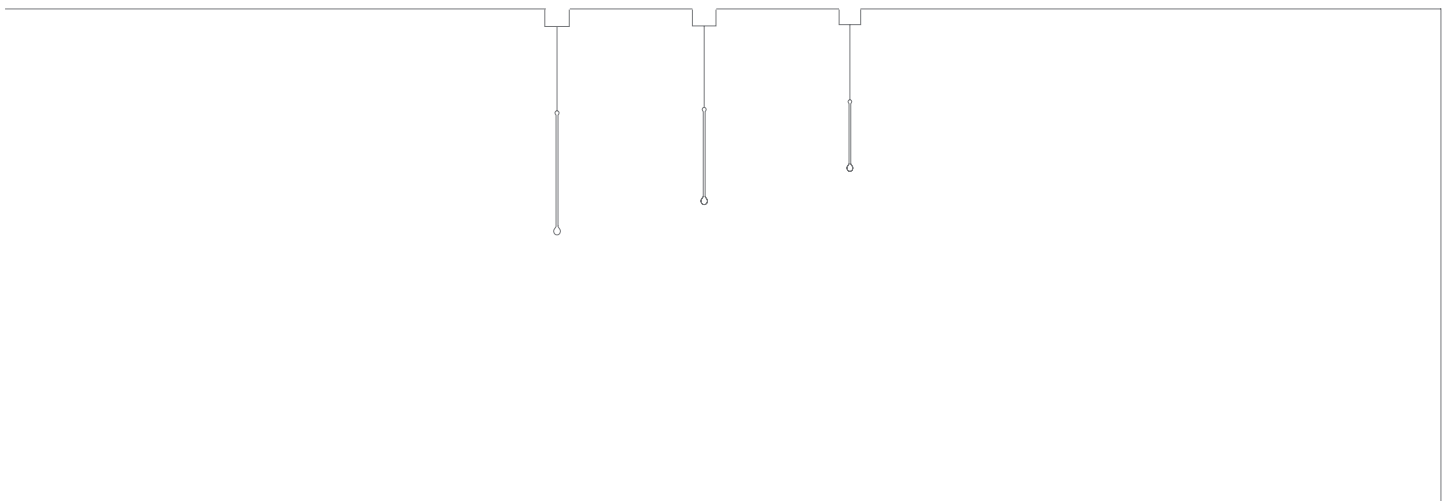





*Creating evocative
— harmonies of light*







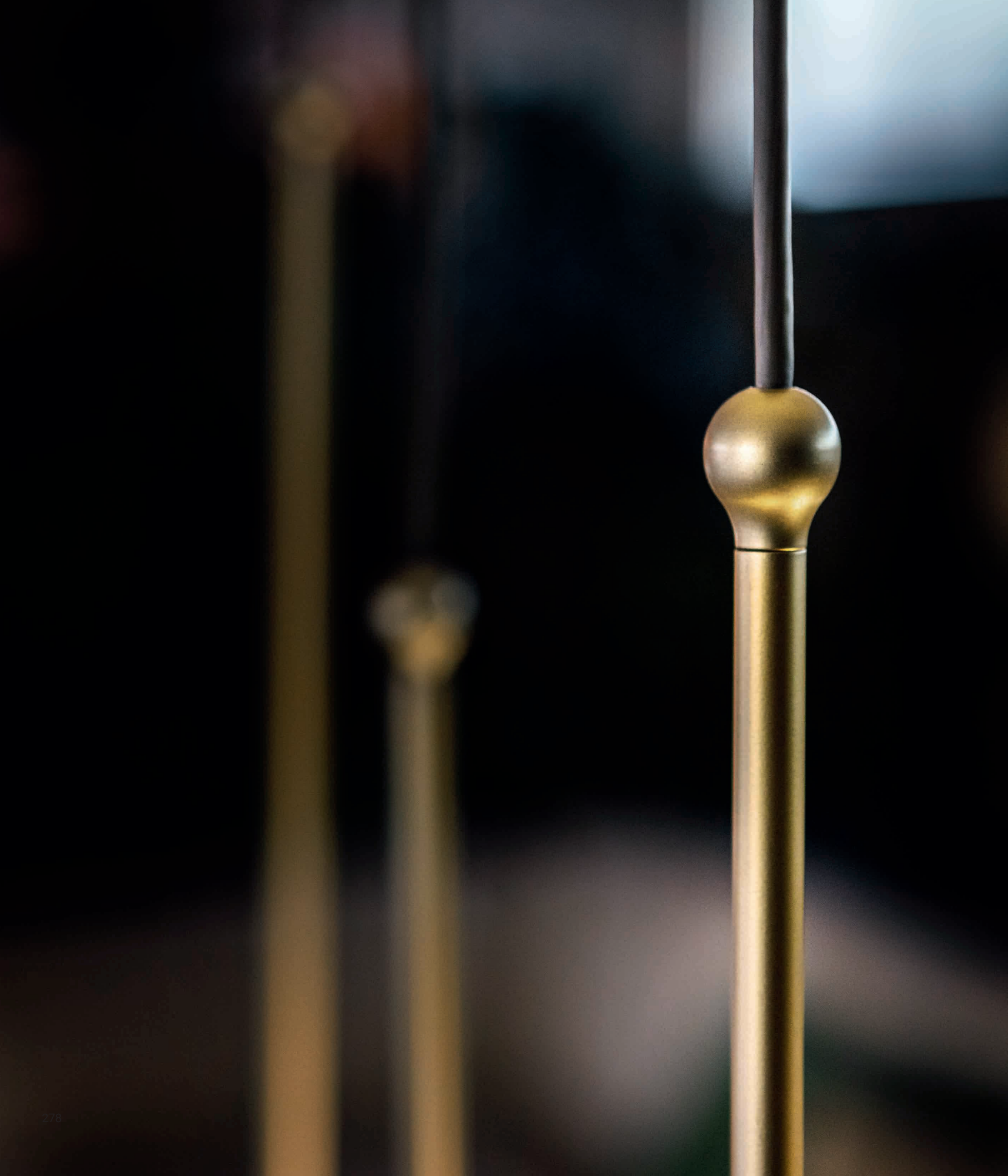

STORM *Bartoli Design, 2017*

1704

Sospensione composta da un'asta in metallo nelle finiture opache: oro, oro rosa e grafite. Disponibile in tre dimensioni: Large, Medium e Mini, utilizzabile come elemento singolo o multiplo. Rosone singolo nelle stesse finiture della struttura.

Pendant lamp made by a metal stick in the mat finishes: gold, rose gold and graphite. Available in three sizes: Large, Medium and Mini as single element or in cluster. Single canopy in the same finishes of the structure.

STRUTTURA METALLO / METAL STRUCTURE

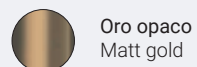

Oro opaco
Matt gold

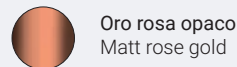

Oro rosa opaco
Matt rose gold

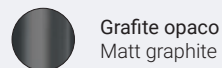

Grafite opaco
Matt graphite

SORGENTE/ SOURCE

4W LED 3000 K - 400 lm

SOSPENSIONE / SUSPENSION

1704-23
large



1704-21
medium



1704-20
mini

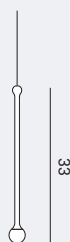

Rosone
Canopy

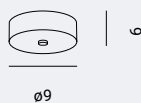

Piastre a pag. 364
plates p. 364

UMBERTO ASNAGO, 2009

T A A A C

Flexible arch — flexible light

Taaac rielabora in forma contemporanea il classico arco, con in più il tocco sartoriale dei dettagli in cuoio a impreziosire la struttura in materiale termoplastico. Protagonista è l'emissione luminosa, i cui parametri illuminotecnici si programmano con il telecomando.

Taaac reworks the classic arch in a contemporary form, with the tailoring touch of leather details to enrich the structure made of thermoplastic. The focus is on the light emission, whose parameters are programmed with the remote control.

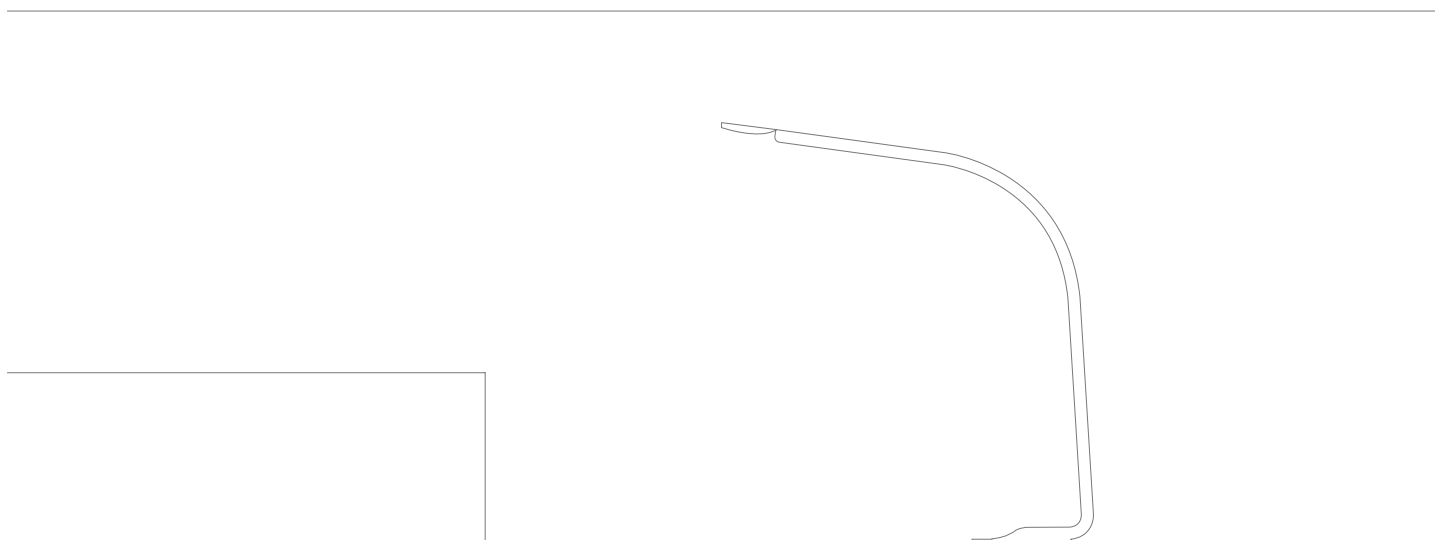









TAAAC *Umberto Asnago, 2009*

0808

Lampada da terra con base in metallo nero gofrato e struttura in espanso termoplastico lucido bianco o nero, o rivestita in cuoio nei colori: bianco, nero, testa di moro, tortora. Orientabile 360°. Luce LED superiore ed inferiore con accensione separata con telecomando.

Floor lamp with base in embossed black metal and structure in glossy thermoplastic expansion white or black, or covered with leather in the colors: white, black, testa di moro, tortora. 360° adjustable. Upper and lower separated LED lighting with remote control.

ESPANSO TERMOPLASTICO / THERMOPLASTIC EXPANSION

 Bianco lucido
Glossy white

 Nero lucido
Glossy black

CUOIO / LEATHER

 Bianco
White

 Nero
Black

 Testa di moro
Testa di moro

 Tortora
Tortora

SORGENTE / SOURCE

3W LED 3500 K - Direct
+
25W LED 2900/5000 K - Indirect

TERRA / FLOOR

0808-10

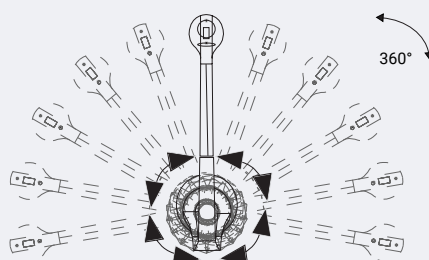
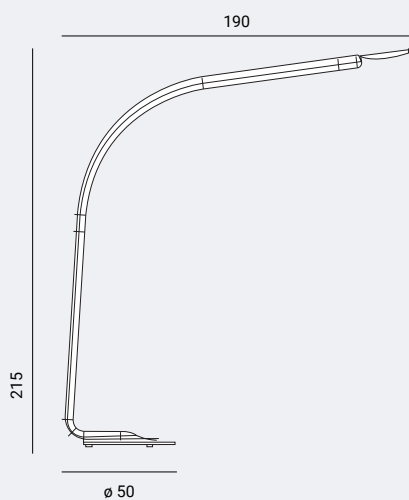

BARTOLI DESIGN 2017

W O N D E R

Astonishing brightness — and beauty

La meraviglia della combinazione di più lampade Wonder di dimensioni, finiture e altezze diverse ha la stessa luminosa bellezza del vetro borosilicato con cui sono realizzate le singole canne, in finitura trasparente o fumé.

Combining more Wonder lamps in different dimensions, finishings and heights is astonishing as the luminous beauty of the borosilicate glass with which every single rod is made, in transparent or fume finishing.

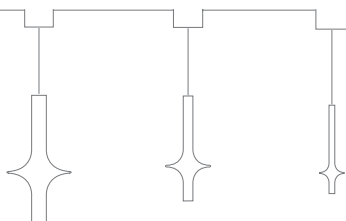









WONDER *Bartoli Design, 2017*

1504

Lampada a sospensione con struttura in metallo nei colori opachi: oro, oro rosa o grafite. Diffusore in vetro borosilicato trasparente o fumé, disponibile in tre dimensioni: large, medium e mini. Rosone singolo nelle stesse finiture della struttura. Utilizzabile come elemento singolo o multiplo.

Pendant with metal structure in the matt colours: gold, rose gold or graphite. Shade in transparent or fume borosilicate glass, supplied in three sizes: large, small and mini. Single canopy in the same finishes of the structure Available as single element or in cluster.

STRUTTURA METALLO / METAL STRUCTURE



Oro opaco
Matt gold



Oro rosa opaco
Matt rose gold



Grafite opaco
Matt graphite

VETRO / GLASS



Trasparente
Transparent



Fumé
Fumé

SORGENTE / SOURCE

4W LED 3000 K - 400 lm

SOSPENSIONE / SUSPENSION

1504-23
large

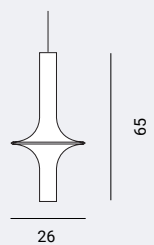

1504-21
medium

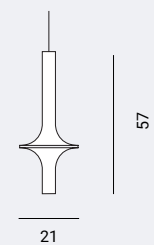

1504-20
mini

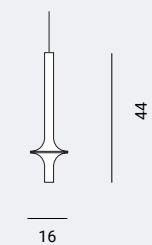

Rosone
Canopy

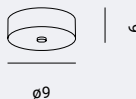

Piastre a pag. 364
plates p. 364

UMBERTO ASNAGO 2015

W O O D Y

The value — of simplicity

Una forma essenziale e iper-contemporanea vestita della ricchezza decorativa del marmo di Carrara: il minimalismo non è mai stato più lussuoso.

A minimal and contemporary shape, along with the decorative opulence of Carrara marble: minimalism has never been so luxurious.





*Minimalism
has never been so luxurious —*







WOODY *Umberto Asnago, 2015*

1406

Lampade a sospensione realizzata in: legno noce canaletto, rovere grigio o in marmo bianco Carrara.

Pendants lamp in walnut wood, grey oak or in Carrara white marble.

FINITURE / FINISHES

-  **Noce Canaletto**
Canaletto walnut
-  **Marmo bianco Carrara**
White Carrara marble
-  **Rovere grigio**
Grey oak

SORGENTE / SOURCE

1406-23
25,5W 24v LED 3000 K

1406-21
12W 24v LED 3000 K

SOSPENSIONE / SUSPENSION

1406-23
large

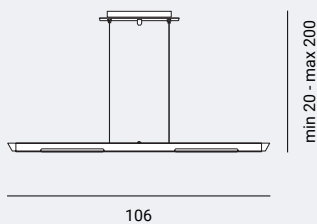

1406-21
small

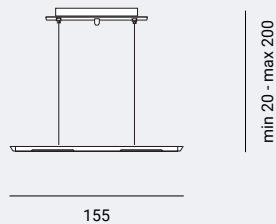



*Una collezione dove l'elemento paralume è protagonista,
un classico made in Penta da riscoprire negli ambienti domestici.*

OUR HERITAGE

*A collection where the lampshade is the protagonist,
a classic Made in Penta to be rediscovered in the cosy setting of a home.*

NEW CLASSIC

Reinventing — the table lamp

Reinterpretazione sofisticata del classico abat-jour, New classic ha una base a bottiglia in vetro di diverse forme e un paralume in tessuto – o in materiale traslucido, per un ulteriore tocco di modernità.

Glamorously reinventing the table lamp, New classic has a glass bottle in different shapes as a base and a shade of fabric or translucent material, for a fresh, contemporary look.

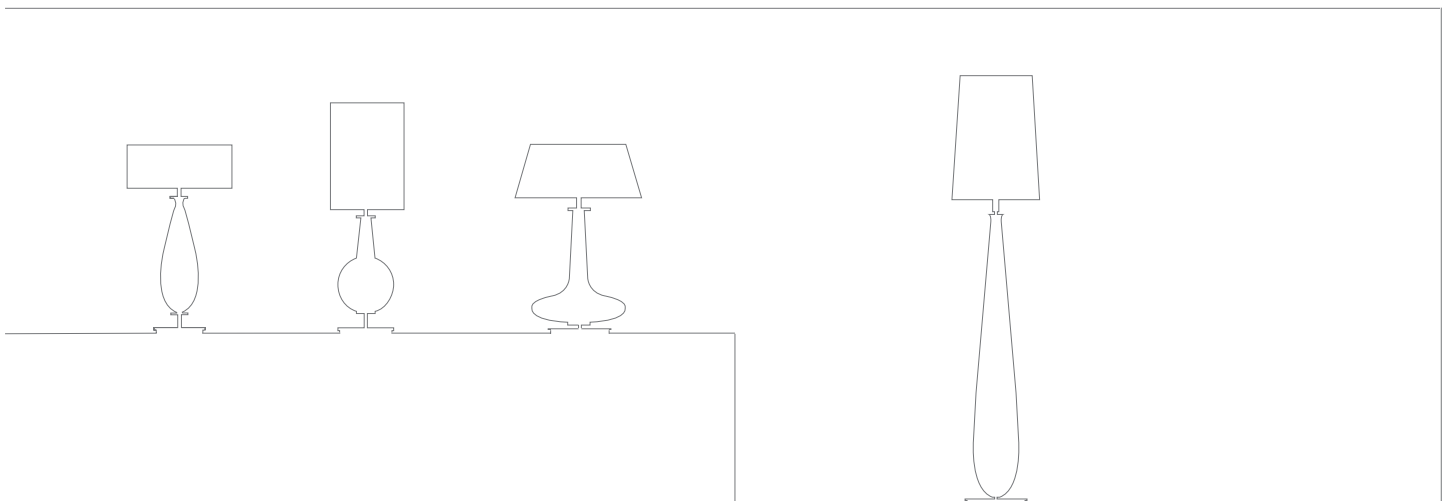



Bon Ton terra
Bon Ton Floor









Bon Ton tavolo
Bon Ton table



Desir tavolo
Desir table





Pascià tavolo
Pascià table





NEW CLASSIC *Umberto Asnago 2003/2008*

0204-5-6

Lampade con struttura in metallo grafite opaco e vetro soffiato nei colori: trasparente, fumé, ambra, rubino, blu, verde oliva. Paralumi intercambiabili in varie misure nei tessuti della collezione, escluso plissé seta a mano. Chiusura superiore totale in plexiglas per lampada da tavolo.

Lamps with structure in matt graphite and blown glass in the following colours: transparent, fumé, amber, ruby, blue, olive-green. Interchangeable shades in different sizes in the fabrics of the collection, hand-made silk plissé excluded. Complete top closure in plexiglas for table lamp only.

PARALUME / SHADE



Tessuti della collezione
Fabrics of the collection

VETRO / GLASS



Trasparente
Transparent



Rubino
Ruby



Fumé
Fumé



Blu
Blue



Ambra
Amber



Verde oliva
Olive-green

TERRA / FLOOR

0204-10
Bon Ton

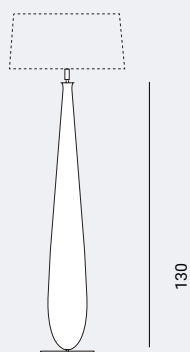

0200-93
Low semicone

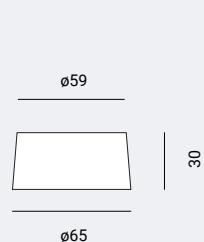

0200-94
High semicone

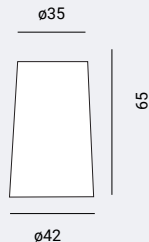

SORGENTE / SOURCE

0204-00
1 x 10W LED E27

0205-00
1 x 10W LED E27

0206-00
1 x 10W LED E27

0204-10
1 x 10W LED E27

TAVOLO / TABLE

0204-00
Bon Ton

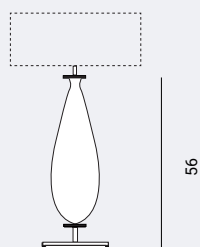

0205-00
Desir

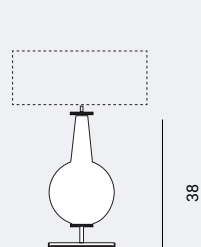

0206-00
Pascià

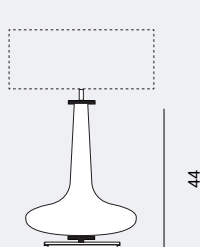

0200-90
Semicone

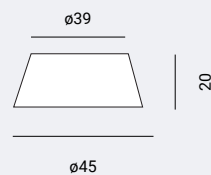

0200-91
High cylinder

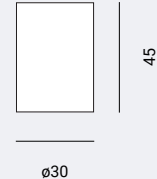

0200-92
Low cylinder

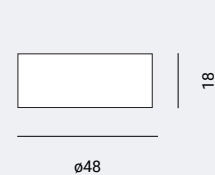

UMBERTO ASNAGO 2013

T I C & T O C

As time — goes by

Luce, trasparenza, leggerezza: la collezione Tic/Toc si compone di due lampade diverse ma affini. La prima è completamente in vetro colorato con un'anima luminosa, la seconda unisce una base a sfera di vetro a un paralume in tessuto.

Light, transparency, lightness: Tic/Toc collection consists of two different but similar lamps. The first one is coloured glass with a bright soul, the second combines a glass sphere with a fabric shade.

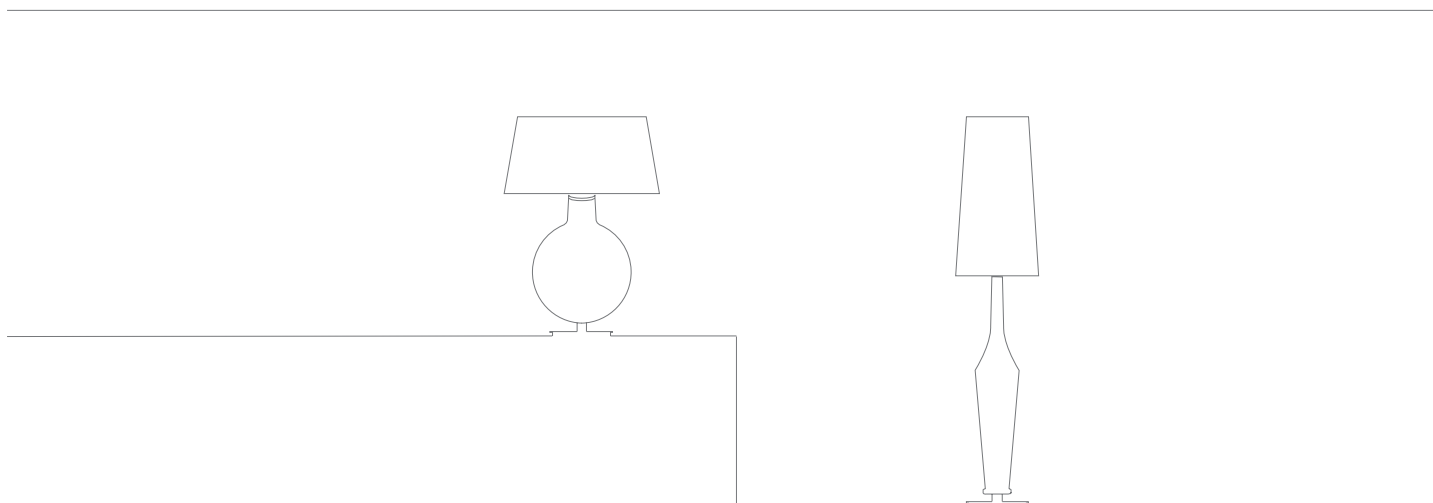



Tic







Toc





TIC & TOC *Umberto Asnago, 2013*

1303-4

Lampade con struttura in metallo grafite opaco e vetro soffiato nei colori: trasparente, fumé, rubino, blu, oliva, ambra. Paralumi intercambiabili nelle forme e nei tessuti della collezione. Escluso plissé seta a mano.

Lamps with structure in matt graphite and blown glass in the following colours: transparent, fumé, ruby, blue, olive-green, amber. Interchangeable shades in different sizes in the fabrics of the collection. Hand-made silk plissé excluded.

PARALUME / SHADE



Tessuti della collezione
Fabrics of the collection

VETRO / GLASS



Trasparente
Transparent



Rubino
Ruby



Fumé
Fumé



Blu
Blue



Ambra
Amber



Verde oliva
Olive-green

SORGENTE / SOURCE

1303-00
1 x 10W LED E27

1304-00
1 x 10W LED E27

TAVOLO / TABLE

1303-00

Tic

ø20/28



56

80

1303-90

Glass shade

ø22



48

ø28

diffusore in vetro
glass shade

1303-91

Fabric Shade

ø20



ø28

1304-00

Toc

ø50/60

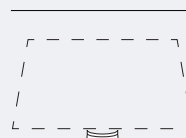

30

52

1304-91

Fabric Shade

ø50



30

60

UMBERTO ASNAGO 2006

T O S C A

Elegant — and pure

Un sostegno essenziale in metallo supporta un paralume rettangolare in tessuto in questa lampada da terra o da tavolo che mostra tutta l'eleganza della semplicità, per un effetto luminoso di grande atmosfera.

A minimal metal support sustains a rectangular fabric shade in this floor or table lamp which shows all the elegance of simplicity, for a light effect of great atmosphere.

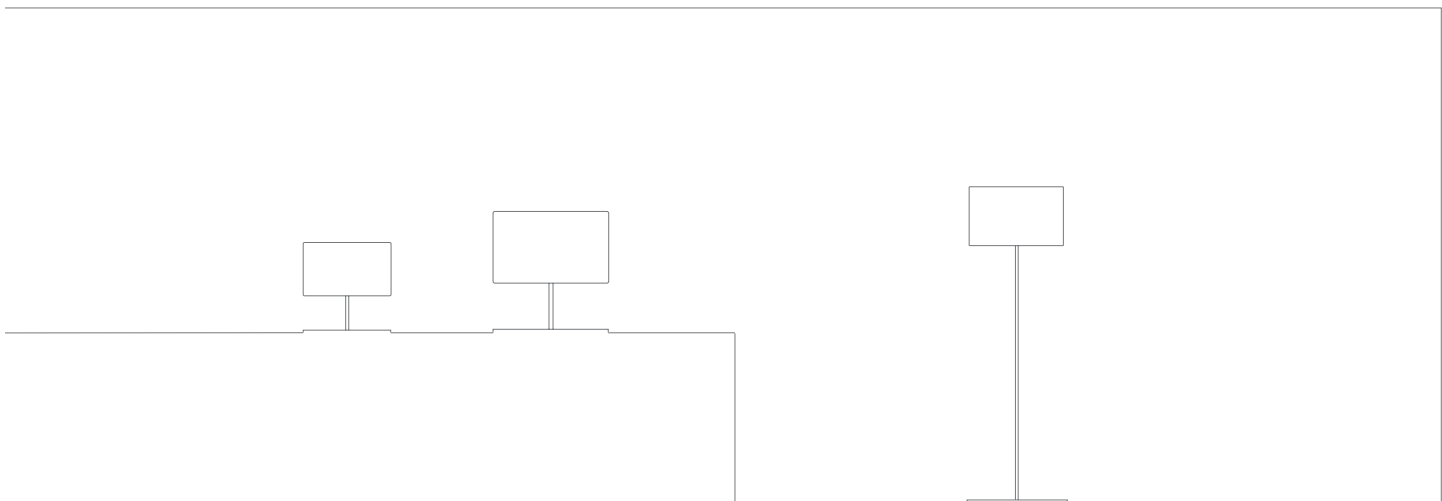









PENTIA

TOSCA *Umberto Asnago, 2006*

0601

Lampade con struttura in metallo grafite opaco. Diffusore nei tessuti della collezione con chiusura superiore in plexiglas.

Lamps with structure in matt graphite. Shade in the fabrics of the collection with top closure in plexiglas.

PARALUME / SHADE



Tessuti della collezione
Fabrics of the collection

STRUTTURA METALLO / METAL STRUCTURE



Grafite opaco
Matt graphite

SORGENTE / SOURCE

0601-03
2 x 5W LED E14

0601-01
2 x 5W LED E14

0601-10
2 x 10W LED E27 

TAVOLO / TABLE

0601-03
large

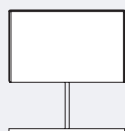

41

0601-90
large

40x13,5



24

0601-01
small

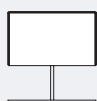

31

0601-91
small

30x10



18

TERRA / FLOOR

0601-10



162

0601-92

50x20

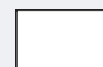

30

BRIDGET

COLLECTION

Night reading — perfection

Una famiglia di lampade dalla forte vocazione progettuale. Nella versione da tavolo dotata di braccio mobile, il paralume si può spostare in base alle esigenze rendendo Bridget la perfetta lampada da lettura.

A family of lamps with a strong design vocation. In the table version, it is equipped with an adjustable arm, so that the shade can be moved according to requirements, and Bridget becomes the perfect reading lamp.

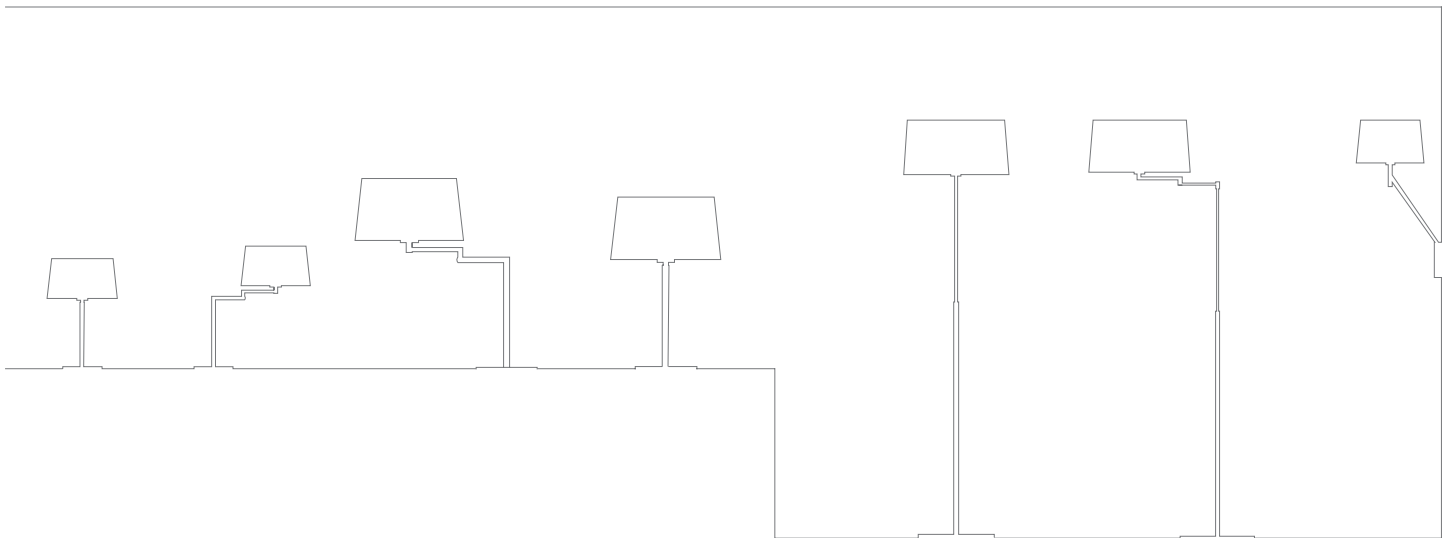





BRIDGET COLLECTION

1003

Lampade con struttura in metallo nichel satinato. Paralume semicono nei tessuti della collezione. (Escluso plissé seta a mano e PVC specchiato). A richiesta per quantitativi: ulteriori finiture metalliche e plissé seta a mano.

Lamps with structure in nickel satin metal. Semicone shade in the fabrics of the collection. (Hand-made silk plissé and mirroring PVC excluded). On demand for quantity: further metal finishes and hand-made silk plissé.

PARALUME / SHADE



Tessuti della collezione
Fabrics of the collection

STRUTTURA METALLO / METAL STRUCTURE



Metallo nichel satinato
Nickel satin metal

SORGENTE / SOURCE

1003-04
8W LED E27

1003-10
10W LED E27

1003-03
8W LED E27

1003-16
10W LED E27

1003-02
5W LED E14

1003-31
5W LED E14

1003-01
5W LED E14

TAVOLO / TABLE

1003-03
large extensible



1003-04
large extensible adjustable

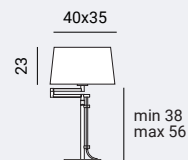

1003-90
large shade

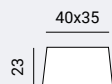

APPLIQUE / WALL

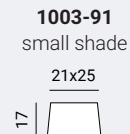
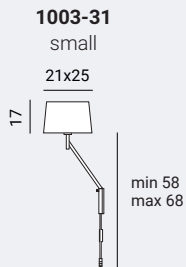

1003-01
small extensible



1003-02
small extensible adjustable



1003-91
small shade



TERRA / FLOOR

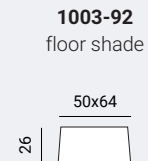
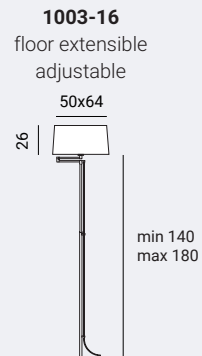
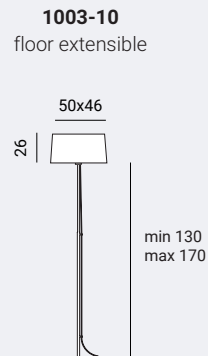



SOSPENSIONI IN TESSUTO

Sospensioni e paralumi in tessuto hanno segnato l'inizio della nostra storia. Ancora oggi li facciamo a mano uno a uno, con tessuti e passamanerie di pregio.



FABRIC SUSPENSIONS

Fabric suspension lamps and lampshades marked the beginning of our history. As of today, we still produce each of them by hand, with precious fabrics and trimmings.

CILINDRO

Classic and soft — to the touch

Un oggetto dalle linee pulite che diventa protagonista dello spazio, esaltando attraverso la luce la morbidezza del tessuto.

An object with clean lines becomes the protagonist of the space, enhancing the softness of the fabric through light.

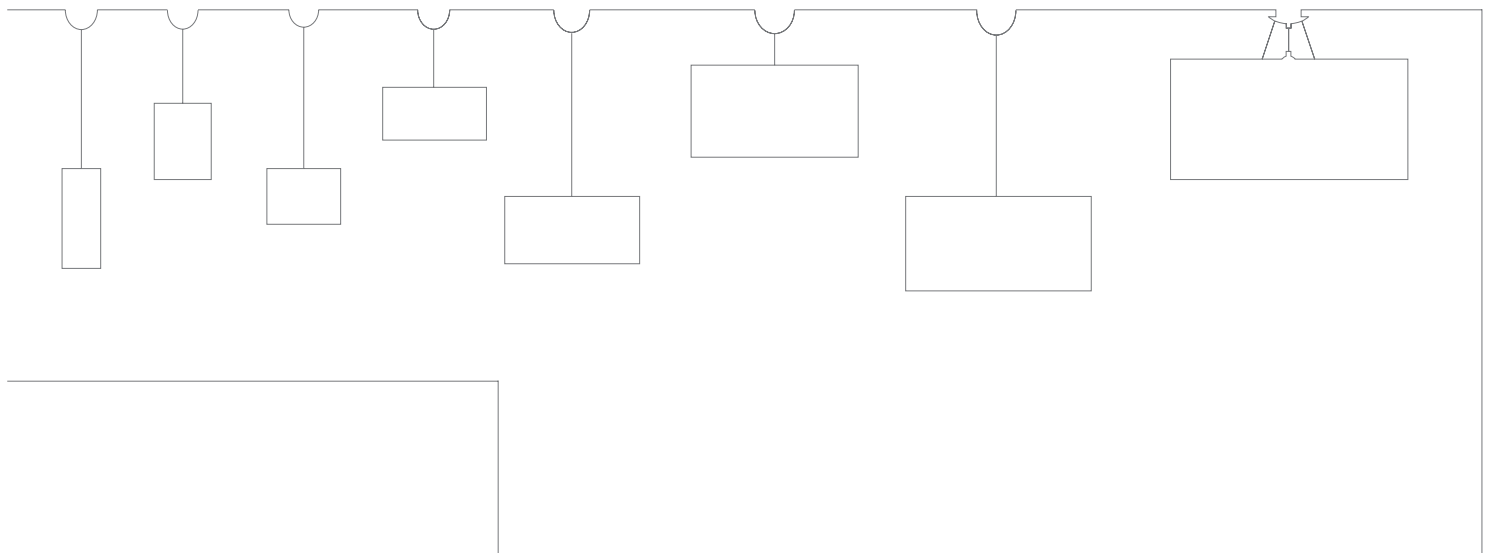



Linone verde lime
Lime green lawn

CILINDRO ALTO

A beautiful — presence

Una sospensione in tessuto dalla forma cilindrica allungata, da usare sola o abbinata ad altre di diametri e altezze diverse, anche in differenti finiture.

A fabric suspension with an elongated cylindrical shape, to be used alone or combined with others of different diameters and heights, in different finishings as well.



Seta rosso e bianco
Red and white silk

CILINDRI BASSI

A cozy — and welcoming light

Una sospensione dal fascino sofisticato: il paralume in tessuto lascia filtrare una luce morbida e accogliente, perfetta per i luoghi della convivialità.

A suspension lamp with a sophisticated charm: the fabric shade leaks a warm, welcoming light, which is perfect for convivial spaces.



Linone corca
Cord lawn



Linone cocco
Coco lawn



Linone melograno
Pomegranata lawn

CILINDRO DOPPIO

From tradition — to contemporary

Uno dentro l'altro, i cilindri creano effetti diversi: dalla versione classica, con doppio paralume in tessuto, a quella più contemporanea, con cilindro interno in PVC specchiato.

One inside the other, the cylinders create different effects: from the classic version, with a double fabric shade, to the more contemporary one, with an internal mirror-finish PVC cylinder.

Pvc argento interno - seta nero esterno
Silver pvc inside - black silk outside



UP - DOWN

The adjustable — lampshade

Il classico paralume rinasce in versione iper-contemporanea in Up&Down, sospensione in tessuto o PVC specchiato con cavo e contrappeso in metallo, da regolare in altezza.

The classic lampshade is new again in this hyper-contemporary version of Up&Down, a suspension lamp in fabric or mirror-finish PVC with a metal cable and counterweight, to be adjusted in height.

Pvc bronzo
Bronze pvc



TESSUTO - FABRICS

LUXURY

Light and pleats — an inseparable pair

Luxury è una sospensione in tessuto resa più ricca dalla lavorazione a plissé. È disponibile nelle forme semiconica, cilindrica e rettangolare.

Luxury is a fabric suspension lamp, enriched by the pleated handwork. It is available in semi-conic, cylindrical and rectangular shape.

Plissé seta a mano tabacco
Hand-made silk plissé tobacco



TESSUTO - FABRICS

SLIDE

Graceful — and bright ceilings

Il cilindro basso in tessuto riletto in versione plafoniera,
per gli spazi di casa e quelli del contract.

The short fabric cylinder in a wall lamp version, for home
and public spaces.

Seta avorio
Ivory silk



R E T T A N
G O L A R E

Geometry — has never been softer

Le curve sinuose dei cilindri lasciano spazio alla geometria di Rettangolo, una sospensione rigorosa riscaldata dalla finitura in tessuto.

The sinuous curves of the cylinders leave space to the geometry of Rettangolo, a severe suspension light, made softer by the fabric finishings.



Lino grezzo
Unbleached linen

TESSUTO - FABRICS

VANITY

An easy — atmosphere

La stessa morbida qualità della luce e la bellezza tattile delle sospensioni in tessuto in versione applique.

The same soft quality of light and the tactile beauty of the fabric suspensions, here in the wall lamp version.

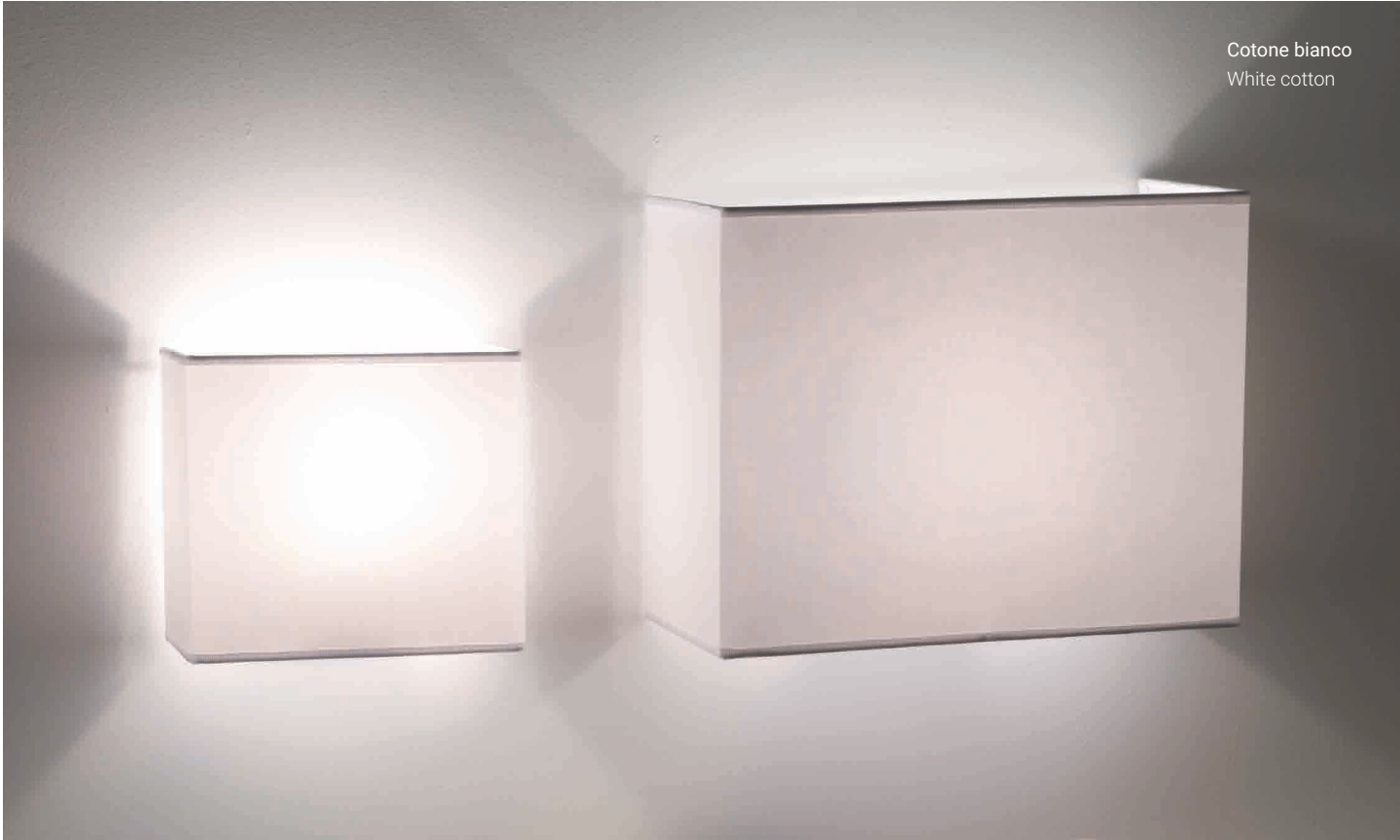

Cotone bianco
White cotton



Cotone bianco
White cotton

TESSUTO - FABRICS

CLUB HOUSE

Classic — with a twist

Club House è una collezione dall'indole decorativa che rilegge con ironia il classico paralume in seta con passamaneria a contrasto.

Club House is a decorative collection that ironically reinterprets the classic silk shade with contrasting trimmings.







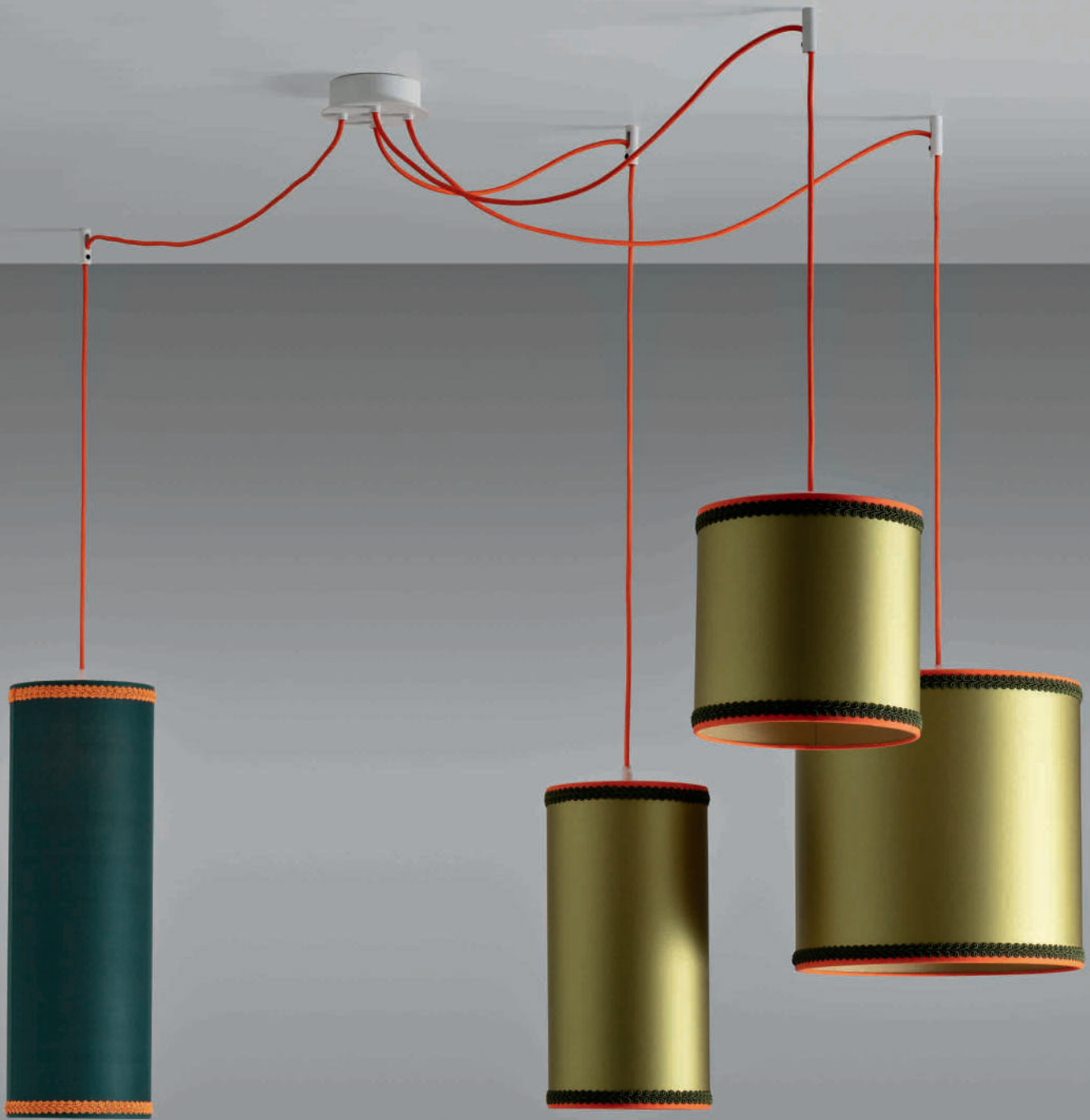

Esempio composizioni

Su progetto a richiesta rosoni e composizioni personalizzate

Composition examples

On demand special canopies and compositions for custom projects

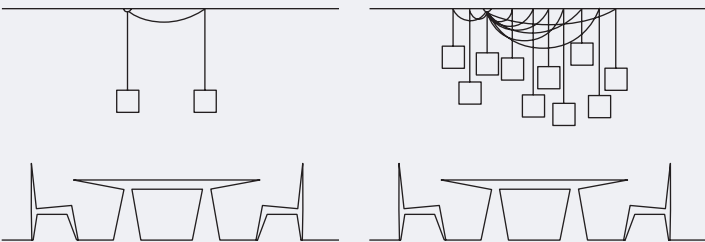
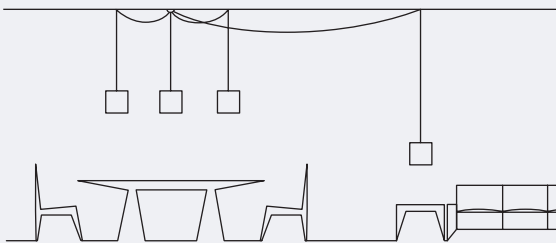
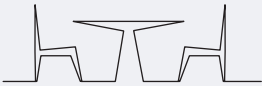
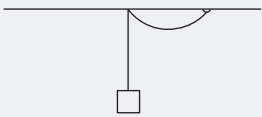
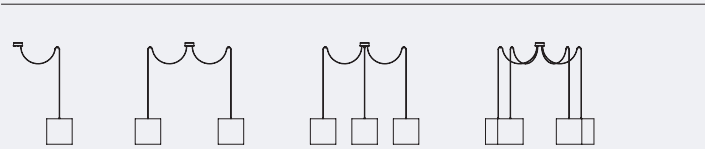

ROSONI / CANOPIES CLUB HOUSE

AD01-T-13-01
white

AD18-T-13-01
titanium



ø13

AD01-T-13-02
white

AD18-T-13-02
titanium



ø13

AD01-T-13-03
white

AD18-T-13-03
titanium



ø13

AD01-T-13-04
white

AD18-T-13-04
titanium



ø13

AD01-T-13-08
white

AD18-T-13-08
titanium



ø13



1402-30-11

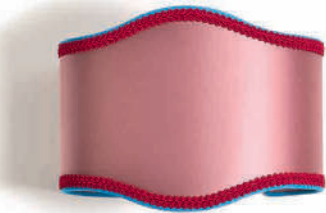

1402-30-07



1402-30-06



1402-30-02



1402-30-01

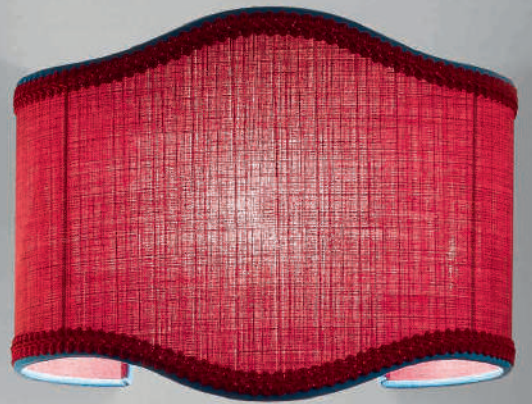

Cavo elettrico in cotone colorato
Electrical cable in cotton colour



Blu
Blue



Turchese
Turquoise



Arancio
Orange



Arancio
Orange



Turchese
Turquoise

Linone - Lawn



Blu Denim
Blue Denim



Melograno
Pomegranate



Verde Lime
Lime green



Cocco
Coco



Corda
Cord

Raso di seta - Silk satin



Blu Marine
Blue Marine



Malva
Mauve



Salvia
Salvia



Fango
Fango



Madreperla
Pearl



TESSUTO / FABRICS

CILINDRI p.332

9229-20
cylinder

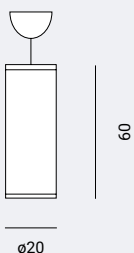

9229-21
cylinder

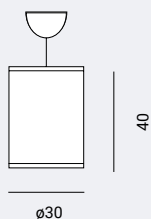

9229-22
cylinder

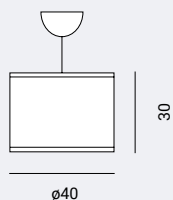

9229-23
cylinder

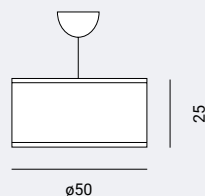

9229-24
cylinder

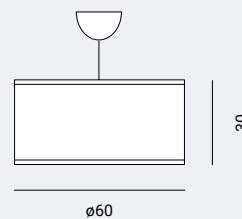

9229-25
cylinder

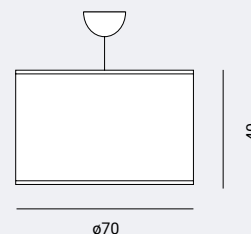

9229-26
cylinder

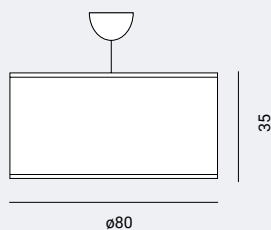

9229-27
cylinder

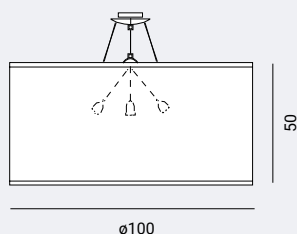

9229-29
double cylinder

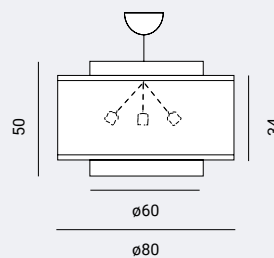

9229-28
cylinder

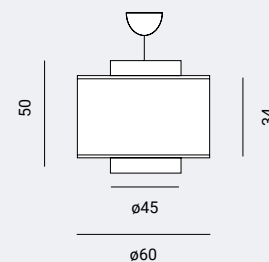

0604-20
low cylinder

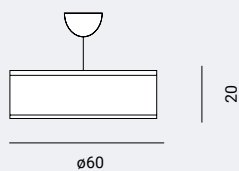

0604-21
low cylinder

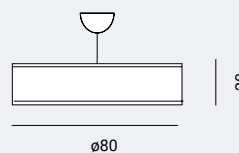

0604-22
low cylinder

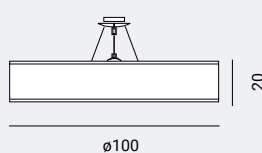

0610-20
high cylinder

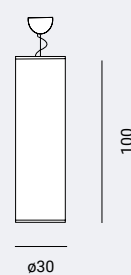

0605-20
high cylinder

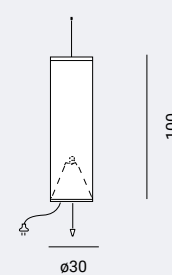

SORGENTE / SOURCE

9229-20
10W LED E27

9229-24
10W LED E27

9229-28
3 x 10W LED E27

0604-22
3 x 10W LED E27

9229-21
10W LED E27

9229-25
10W LED E27

9229-29
3 x 10W LED E27

0610-20
10W LED E27

9229-22
10W LED E27

9229-26
10W LED E27

0604-20
3 x 10W LED E27

0605-20
10W LED E27

9229-23
10W LED E27

9229-27
3 x 10W LED E27

0604-21
3 x 10W LED E27

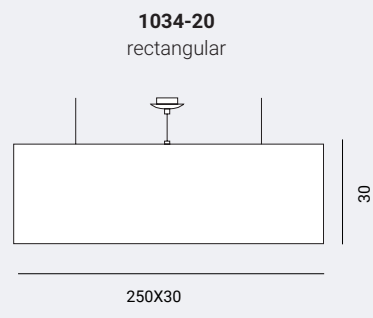
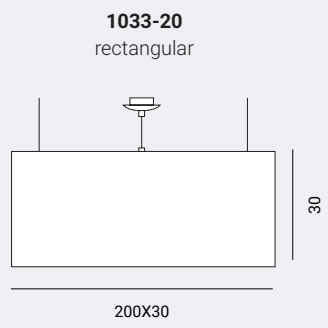
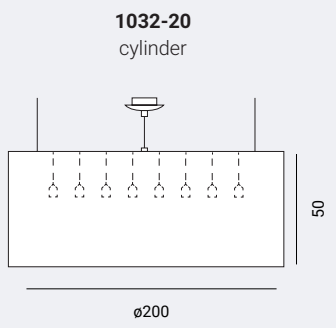
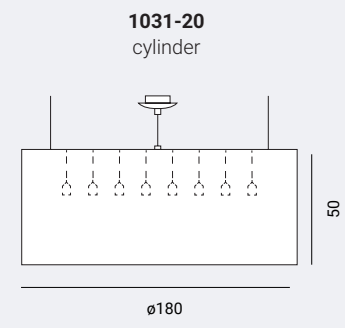
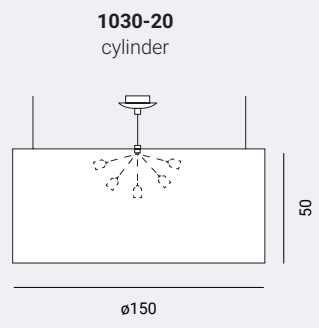
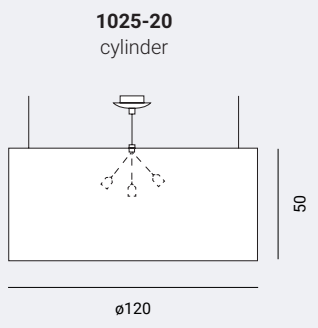
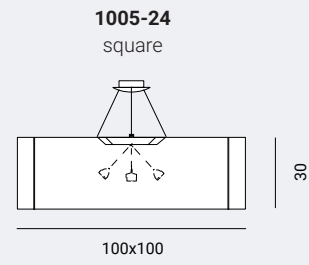
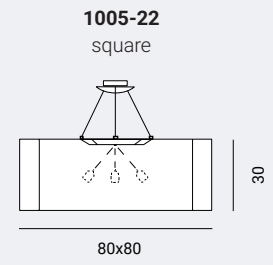
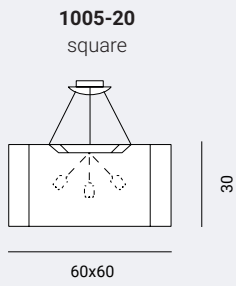

UP-DOWN p. 340

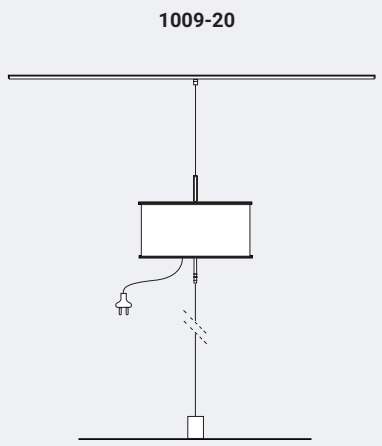

SORGENTE/ SOURCE

1005-20
3 x 10W LED E27

1005-21
3 x 10W LED E27

1005-22
3 x 10W LED E27

1025-20
3 x 10W LED E27

1030-20
5 x 10W LED E27

1031-20
8 x 10W LED E27

1032-20
8 x 10W LED E27

1033-20
4 x 10W LED E27

1034-20
4 x 10W LED E27

1009-20
3 x 5W LED E14

TESSUTO / FABRICS

LUXURY p. 342

0607-20
semicone

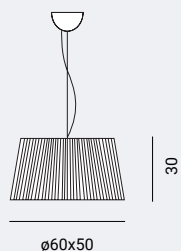

0607-21
semicone

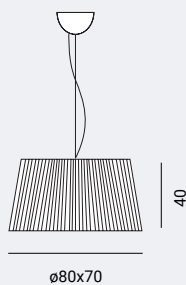

0607-22
semicone

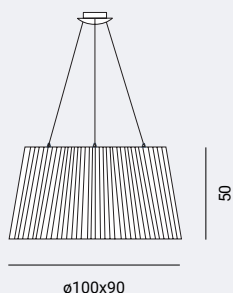

0607-23
cylinder

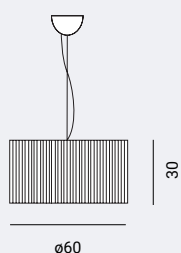

0607-24
cylinder

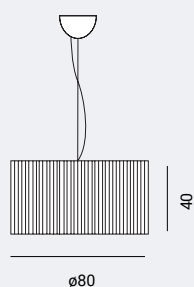

0607-25
cylinder

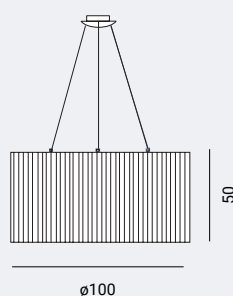

0607-26
rectangular

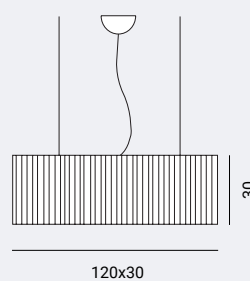

SLIDE p. 344

0604-40
small round

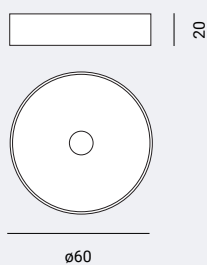

0604-41
medium round

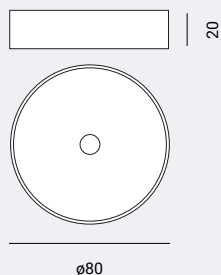

0604-42
large round

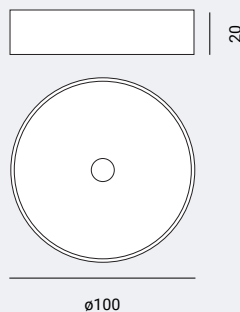

1005-40
small square

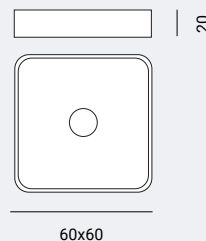

1005-41
medium square

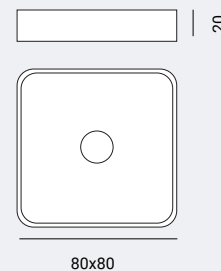

1005-42
large square

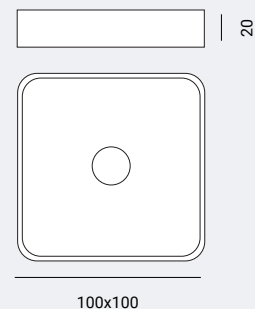

SORGENTE/ SOURCE

0607-20
3 x 10W LED E27

0607-23
3 x 10W LED E27

0607-26
3 x 10W LED E27

0604-42
3 x 10W LED E27

1005-42
3 x 10W LED E27

0607-21
3 x 10W LED E27

0607-24
3 x 10W LED E27

0604-40
3 x 10W LED E27

1005-40
3 x 10W LED E27

0607-22
3 x 10W LED E27

0607-25
3 x 10W LED E27

0604-41
3 x 10W LED E27

1005-41
3 x 10W LED E27

CLUB HOUSE p. 350

1402-20

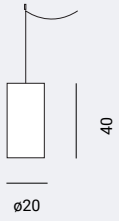

1402-21

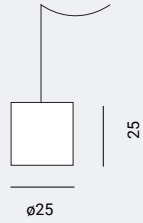

1402-22

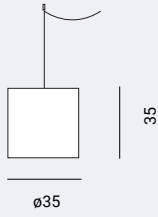

Rosone
Canopy

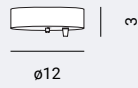

1402-24
trendy large

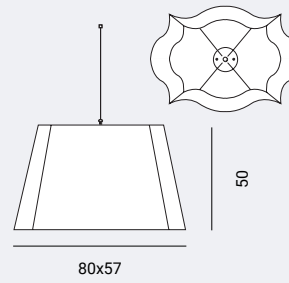

1402-23
trendy small

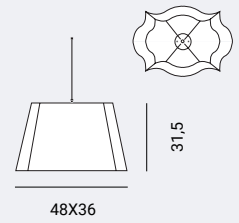

1402-30



1402-31



1402-32



1402-33



1402-34

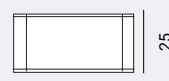

VANITY p. 348

9540-31

large rectangular

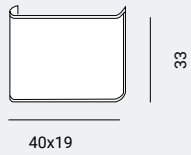

9540-30

small rectangular

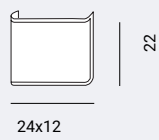

9540-33

large round

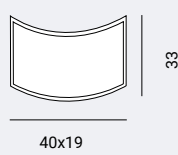

9540-32

small round

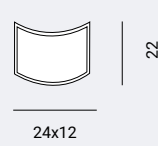

SORGENTE/ SOURCE

1402-20
10W LED E27

1402-23
10W LED E27

1402-31
10W LED E27

1402-34
10W LED E27

9540-32
5W LED E14

1402-21
10W LED E27

1402-24
3 x 10W LED E27

1402-32
10W LED E27

9540-30
5W LED E14

9540-33
10W LED E27

1402-22
10W LED E27

1402-30
10W LED E27

1402-33
10W LED E27

9540-31
10W LED E27

PIASTRE / PLATES

A-PIASTRE / PLATES ACORN, GLO, LIT, MOM

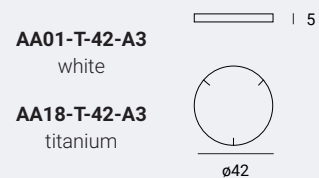

Piastra tonda con max 3 attacchi
Round plate with max 3 fittings

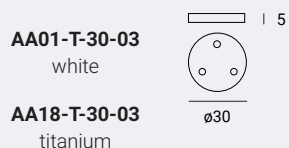

Piastra tonda con max 3 attacchi
Round plate with max 3 fittings

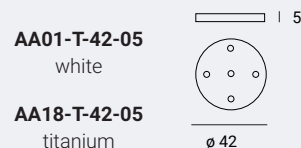

Piastra tonda con max 5 attacchi
Round plate with max 5 fittings

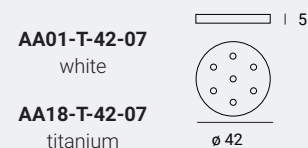

Piastra tonda con max 7 attacchi
Round plate with max 7 fittings

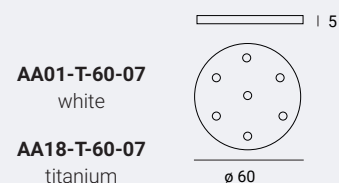

Piastra tonda con max 7 attacchi
Round plate with max 7 fittings

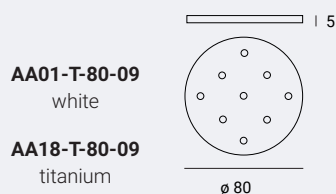

Piastra tonda con max 9 attacchi
Round plate with max 9 fittings

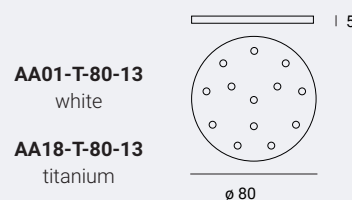

Piastra tonda con max 13 attacchi
Round plate with max 13 fittings

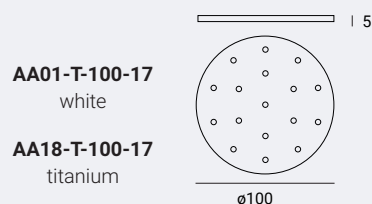

Piastra tonda con max 17 attacchi
Round plate with max 17 fittings

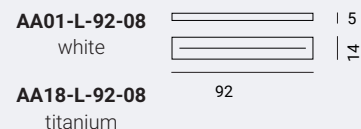

Piastra lineare con max 8 attacchi
Round plate with max 8 fittings

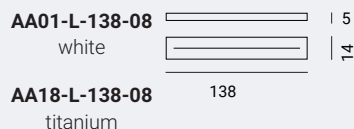

Piastra lineare con max 8 attacchi
Round plate with max 8 fittings

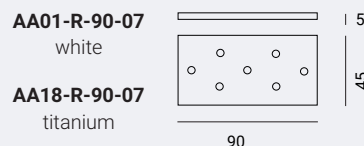

Piastra rettangolare con max 7 attacchi
Rectangular plate with max 7 fittings

D-PIASTRE / PLATES STORM, SPOON



max 3 attacchi
max 3 fittings

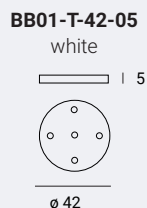

max 5 attacchi
max 5 fittings

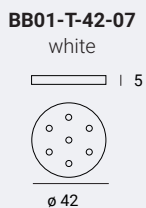

max 7 attacchi
max 7 fittings

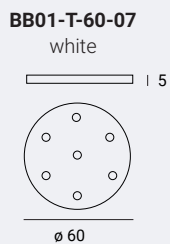

max 7 attacchi
max 7 fittings

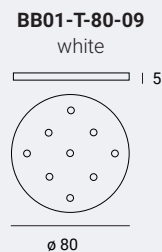

max 9 attacchi
max 9 fittings

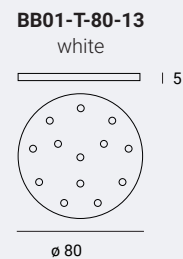

max 13 attacchi
max 13 fittings

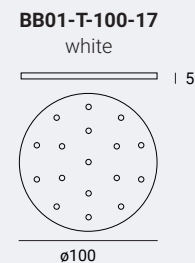

max 17 attacchi
max 17 fittings

BB01-L-92-08
white
max 8 attacchi
max 8 fittings

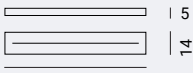

92
5
14

BB01-L-138-08
white
max 8 attacchi
max 8 fittings

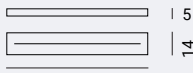

138
5
14

BB01-R-90-07
white
max 7 attacchi
max 7 fittings

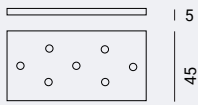

90
45
5

C-PIASTRE / PLATES CLIP

CC01-T-30-03
white
max 3 attacchi
max 3 fittings

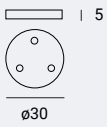

30
5

CC01-T-42-05
white
max 5 attacchi
max 5 fittings

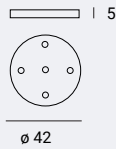

42
5

CC01-T-42-07
white
max 7 attacchi
max 7 fittings

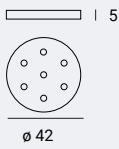

42
5

CC01-T-60-07
white
max 7 attacchi
max 7 fittings

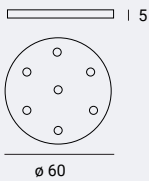

60
5

CC01-T-80-09
white
max 9 attacchi
max 9 fittings

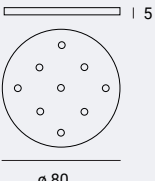

80
5

CC01-T-80-13
white
max 13 attacchi
max 13 fittings

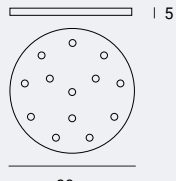

80
5

CC01-T-100-17
white
max 17 attacchi
max 17 fittings

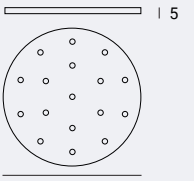

100
5

CC01-L-92-08
white
max 8 attacchi
max 8 fittings

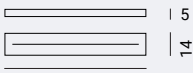

92
5
14

CC01-L-138-08
white
max 8 attacchi
max 8 fittings



138
5
14

CC01-R-90-07
white
max 7 attacchi
max 7 fittings

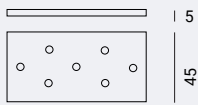

90
45
5

D-PIASTRE / PLATES WONDER

DD01-T-30-03
white
max 3 attacchi
max 3 fittings

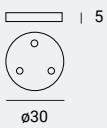

30
5

DD01-T-42-05
white
max 5 attacchi
max 5 fittings

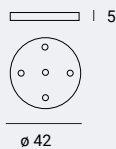

42
5

DD01-T-42-07
white
max 7 attacchi
max 7 fittings

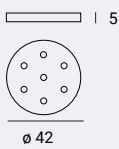

42
5

DD01-T-60-07
white
max 7 attacchi
max 7 fittings

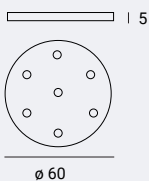

60
5

DD01-T-80-09
white
max 9 attacchi
max 9 fittings

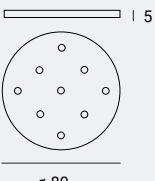

80
5

DD01-T-80-13
white
max 13 attacchi
max 13 fittings

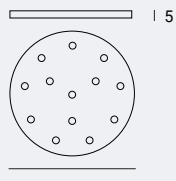

80
5

DD01-T-100-17
white
max 17 attacchi
max 17 fittings

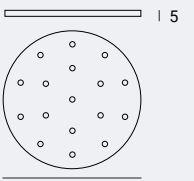

100
5

DD01-L-92-08
white
max 8 attacchi
max 8 fittings

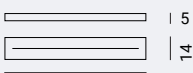

92
5
14

DD01-L-138-08
white
max 8 attacchi
max 8 fittings



138
5
14

DD01-R-90-07
white
max 7 attacchi
max 7 fittings



90
45
5

LEGENDA/ KEYS



Lampadina esclusa/ bulb not included



LED integrato/ integrated LED



Dimmer incluso/ Dimmer included

La tensione s'intende 230V, 50/60HZ o 120V, 60HZ a seconda dei paesi.
Voltage: 230V, 50/60HZ or 120V, 60 HZ according to the country.

I lumen non sempre corrispondono. Verificare sempre le dimensioni. Rif. Leuci
Lumen don't always match. Always check the dimensions. Ref. Leuci

Penta si riserva il diritto di apportare ai propri modelli, senza alcun preavviso, modifiche e migliorie che potrebbero variare l'estetica delle soluzioni pensate.
Penta reserves the right to charge, better and improve its models without notice, also if these improvements might change the aestetical image of the proposed solutions.

I vetri realizzati rigorosamente a mano dal maestro vetraio rispettano le antiche e tradizionali tecniche di soffiatura. Ogni articolo è sottoposto a meticolosi controlli di qualità, pertanto apparenti difetti come bolle o variazioni dei toni di colore del vetro, sono riconosciuti come pregi e conferma della lavorazione artigianale.

Glasses are hand made and mounth blown by the master glass blower, according to the traditional techniques of blowing. Each item is carefully checked, therefore apparent imperfections, such as bubbles or nuances in the glass colour, have to be recognised as qualities and sign of the artisan's craftsmanship.



SISTEMA DI GESTIONE
QUALITÀ CERTIFICATA
AZIENDA CERTIFICATA

ECOLIGHT
EFFICIENZA E PROFESSIONALITÀ PER L'AMBIENTE

PENTA srl aderisce al Consorzio Ecolight per l'attuazione delle direttive WEEE/RAEE 2002/95/CE e 2003/108/CE relative alla raccolta e smaltimento delle apparecchiature di illuminazione.

Penta srl takes part in Consorzio Ecolight for the implementation of directive WEEE/RAEE 2002/95/CE e 2003/1087/CE relating to collection and discharge of lighting fittings.

AD
Nicola Gallizia

STYLING
Carola Minotti

PHOTO
Tiziano Sartorio

FOTOLITO
GM studio 1Vr

STAMPA
IMOCO GROUP

Printed: May 2019



PENTA is part of PENTA GROUP



PENTA srl · via Trieste, snc · 20821 Meda · (MB) · Italy
T +39 0362 1869300
pentalight.it - pentalightgroup.it - info@pentalight.it

MADE IN ITALY 100%

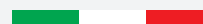



pentalightgroup.it